

# **J E T**

**719A**

**WOODWORKING MORTISER**

**1791263M**

**230/50/1**

**PARTS LIST  
ERSATZTEILLISTE  
LISTE DE PIECES**

**WMH Tool Group AG**

Bahnstrasse 24, CH – 8603 Schwerzenbach

[www.wmhtoolgroup.ch](http://www.wmhtoolgroup.ch); [inf@wmhtoolgroup](mailto:inf@wmhtoolgroup)

Tel +41 (0) 1 806 47 48

Fax +41 (0) 1 806 47 58



# Mortiser Assembly

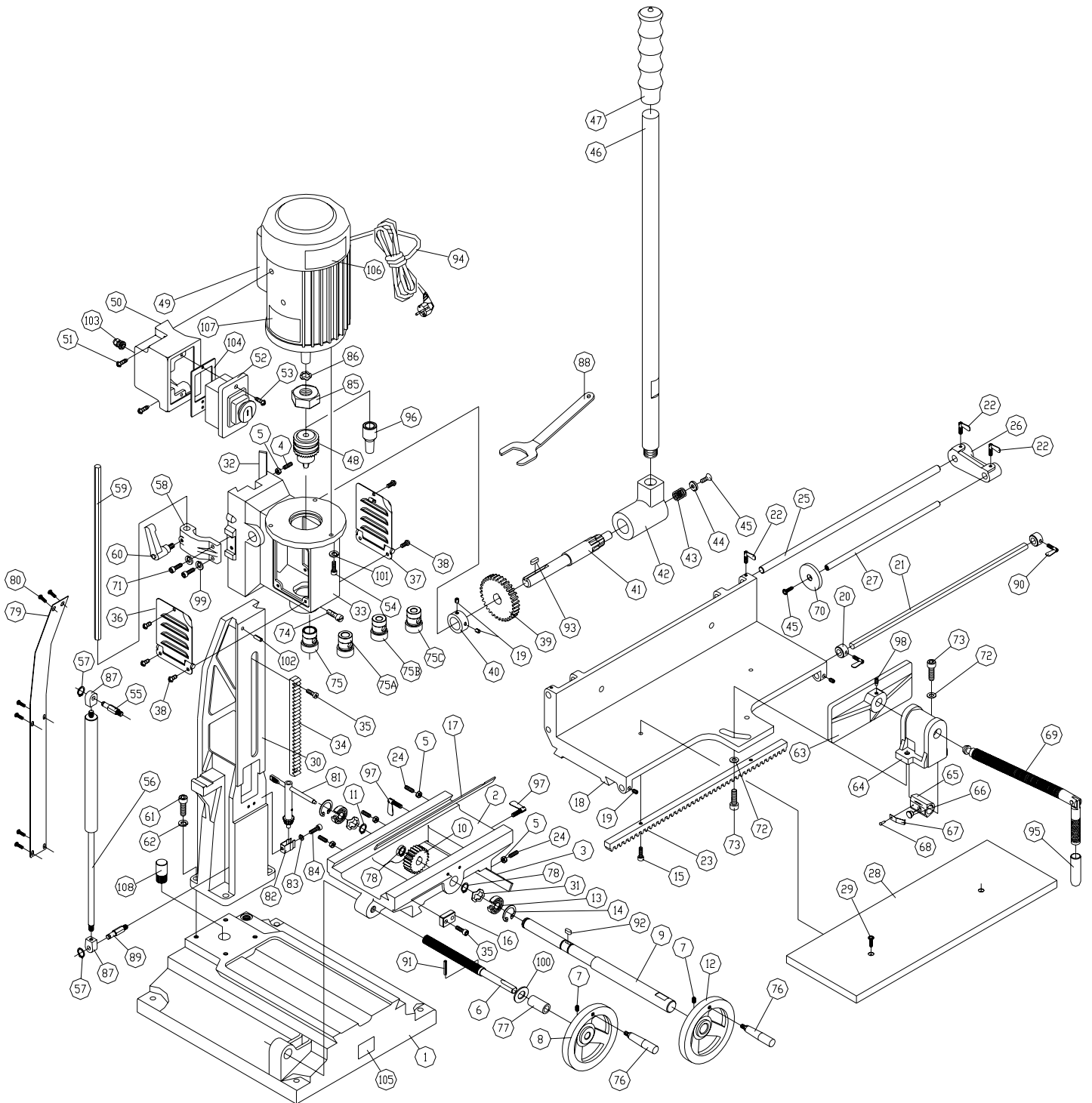

## Parts List : Model 719A Mortiser Assembly

Index No.	Part No.	Description	Size	Qty.
1	6294124	Base		1
2	6294125	Base, Middle		1
3	6294126	Gib	M6x20	1
4	6294127	Set Screw		3
5	6294128	Hex Nut	M6	9
6	6294129	Lead Screw		1
7	6294130	Set Screw	M6x10	4
8	6294131	Handwheel		1
9	6294132	Shaft		1
10	6294133	Gear		1
11	6294134	C-Clip		1
12	6294135	Handwheel		1
13	6294136	Bearing	6002ZZ	2
14	6294137	C-Clip		2
15	6294138	Hex Socket cap Screw	M6x16	2
16	6294139	Setting Piece		1
17	6294140	Gib		1
18	6294141	Slide		1
19	6294142	Set Screw	M6x6	4
20	6294143	Setting Collar		2
21	6294144	Setting Rod		1
22	6294145	Wing Screw	M6x16	3
23	6294146	Pinion		1
24	6294147	Set Screw	M6x25	6
25	6294148	Rear Length Setting Rod		1
26	6294149	Setting Length Block		1
27	6294150	Front Length Setting Rod		1
28	6294151	Work Table		1
29	6294152	Philip Head Screw	M6x20	2
30	6294153	column		1
31	6294154	Wave Washer		2
32	6294155	Gib		1
33	6294156	Headstock		1
34	6294157	Pinion		1
35	6294158	Hex Socket cap Screw	M6x12	4
36	6294159	Left Side Cover		1
37	6294160	Right Side Cover		1
38	6294161	Round Head Screw	M5x12	6
39	6294162	Gear		1
40	6294163	Collar		1
41	6294164	Gear Shaft		1
42	6294165	Clutch Block		1
43	6294166	Spring		1
44	6294167	Flat Washer		1
45	6294168	Flat Head Screw	M6x16	2
46	6294169	Handle		1
47	6294170	Handle Grip		1
48	6294171	Chuck	1/2" & KEY	1
49	6294172	Motor	1HP, 1ph, 230v	1
50	6294173	Switch Box		1

Index No.	Part No.	Description	Size	Qty.
51	6294174	Hex Socket Cap Screw	M5x25	2
52	6294175E	Magnetic Switch		1
53	6294176	Round Head Screw		2
54	6294177	Hex Socket Cap Screw	M6x20	3
55	6294178	Upper Cylinder Fitting		1
56	6294179	Hydraulic Cylinder		1
57	6294180	C-Clip		2
58	6294181	Depth Setting Block		1
59	6294182	Depth Stop		1
60	6294183	Lock Handle		1
61	6294184	Hex Socket Cap Screw	M10x30	4
62	6294185	Lock Washer		4
63	6294186	Clamping Jaw		1
64	6294187	Clamping Block		1
65	6294188	Rapid Nut		1
66	6294189	Friction Toe		1
67	6294190	Spring		1
68	6294191	Rivet		1
69	6294192	Locking Screw		1
70	6294193	Stop Disc		1
71	6294194	Hex Socket Cap Screw	M8x25	2
72	6294195	Flat Washer		2
73	6294196	Hex Socket Cap Screw	M8x30	2
74	6294197	Chisel Locking Screw		1
75	6294198	Bushing	3/4"	1
75A	6294221	Bushing	5/8"	1
75B	6294222E	Bushing	13/16"	1
75C	6294224E	Bushing	1-3/16"	1
76	6294199	Handlewheel		1
77	6294200	Collar		2
78	6294201	E-Clip		1
79	6294202	Back Cover		1
80	6294203	Round Head Screw	M4x10	6
81	6294204	Chuck Key		1
82	6294205	Chuck Key Holder		1
83	6294206	Lock Washer		1
84	6294207	Hex Socket Cap Screw	M5x8	1
85	6294208	Chuck Release Nut		1
86	6294209	Wave Washer		1
87	719A-87	Cylinder Head		2
88	6294211	Wrench		1
89	6294212	Lower Cylinder Fitting		1
90	6294213	Wing Screw		2
91	6294214	Spring Pin		1
92	6294215	Key		1
93	6294216	Key		1
94	6294217E	Power Cord(VDE)		1
95	6294223	Handle Protector		1
96	3005069	Chuck Extension (Adaptor)		1
	6294233	Hardware kit		
97	719A-97	Wing Screw	M6x25L	2
98	719A-98	Set Screw	1/4 x1/2	2
99	6294220	Lock Washer	M8	2
100	719A-100	Flat Washer		1

<b>Index No.</b>	<b>Part No.</b>	<b>Description</b>	<b>Size</b>	<b>Qty.</b>
101	719A-101	Lock Washer	M6	3
102	719A-102	Pin	M5x20L	
103	719A-103E	Strain Relief Bushing (VDE- PG11)		1
104	719A-104E	Switch Plate		1
105	719A-105E	I.D Label		1
106	23010045	JET Label		1
107	719A-107E	Motor Label		1
108	719A-108	Pin		1

-

# Stand Assembly

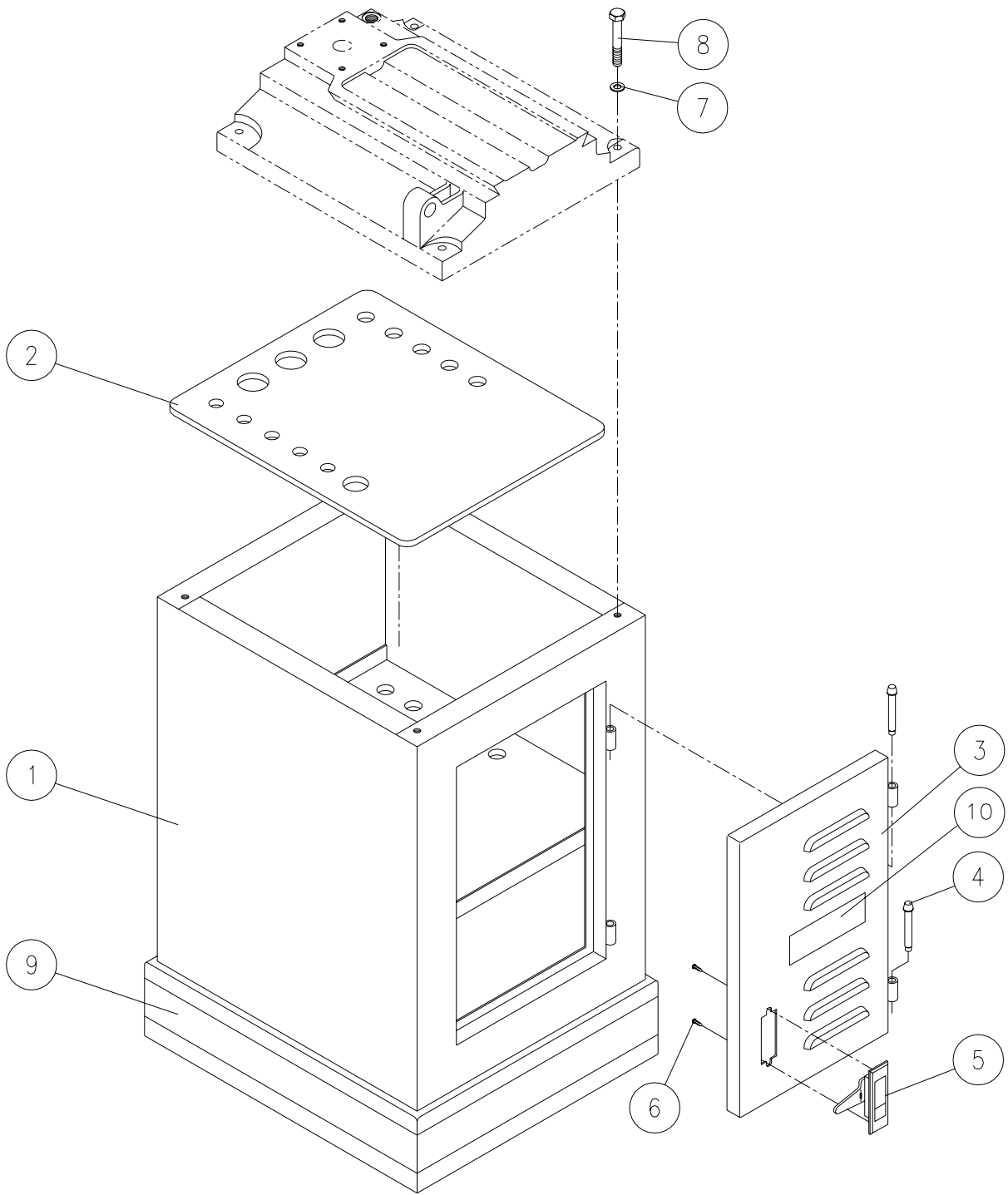

**Parts List : 719A Stand Assembly**

Index No.	Part No.	Description	Size	Qty.
	6294235	Stand Assy (Items 1 thru 8)		
1	6294218	Stand		1
2	6294225	Sponge		1
	6294236	Door Assy		
3	6294226	Door		1
4	6294227	Pin		2
5	6294228	Door Latch		1
6	6294229	Screw	M3	2
7	6294220	Lock Washer	M8	4
8	6294219	Hex Head Screw	M8x60	4
9	JWS34-79S	Stripe		1
10	JWS34-184	JET Label		1

-

# Workpiece Hold Down Assembly (Optional)

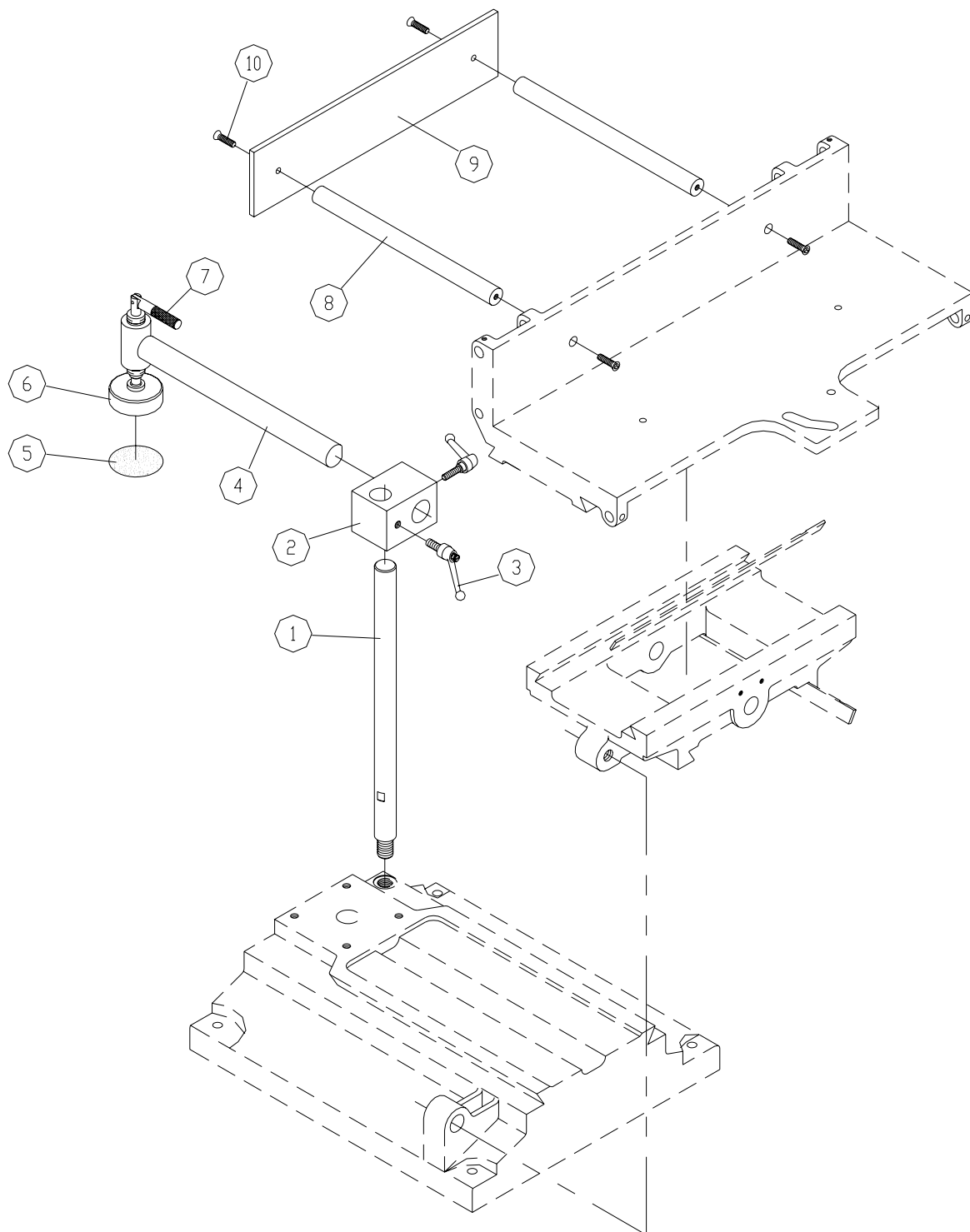



**Parts List : 719A Workpiece Hold Down Assembly (Optional)**

Index No.	Part No.	Description	Size	Qty.
1	23045006	Fix Shaft		1
2	23045005	Fix Shaft bracket.		1
3	42011101	Lock Handle		2
4	23045003	Hold Down Shaft		1
5	23045004	Abrasive		1
6	33015004	Hold Down		1
7	23045007	Lock Handle		1
8	23045002	Fix Shaft		2
9	23045001	Fence		1
10	50108007	Pan Head Screw	M6 x 20	4

-



719A

1791263M

	colour of strands	Litzenfarben	couleur des cordons
BK	black	schwarz	noir
WH	white	weiß	blanc
BU	blue	blau	bleu
YE	yellow	gelb	jaune
RD	red	rot	rouge
BN	brown	braun	brun
GY	grey	grau	gris
GNYE	green-yellow	grün-gelb	vert-jaune
OG	orange	orange	orange
VT	violet	violett	violet

	meaning of symbol	Bedeutung der Zeichen	interprétation
M	motor	Motor	moteur
S	switch	Schalter	interrupteur
C	condenser	Kondensator	condensateur
E	electronic unit	Elektronik Einheit	unité électronique
F	fuse	Sicherung	fusible
RS	reversing switch	Drehrichtungsschalter	commu. droite/gauche
CS	centrifugal switch	Fliehkraftschalter	déclencheur centrifuge
OL	overload cut-off	Überlastschutzschalter	déclencheur surcharge
LS	limit switch	Positionsendschalter	micro

230/50/1

