

J E T

GH-2280ZX

380/50/3

Parts List

WMH Tool Group AG

Bahnstrasse 24,

CH – 8603 Schwerzenbach

www.wmhtoolgroup.ch

info@wmhtoolgroup.ch

Tel +41 (0)44 806 47 48

Fax +41 (0) 44 806 47 58

M-321930T, 321950T, 321960T, 321970T,
321980T, 321990T, 50000772T, 50000775T...06/06



Table of Contents

Table of Contents	2
Stand Assembly	3
Brake Assembly	6
Bed Assembly	8
Headstock Assembly I	11
Headstock Assembly II	14
Headstock Assembly III	17
Headstock Assembly IV	19
Change Gear Box Assembly I	21
Change Gear Box Assembly II	23
Quick Change Gear Box I	25
Quick Change Gear Box II	28
Quick Change Gear Box III	30
Apron Assembly I	32
Apron Assembly II	35
Apron Assembly III	38
Carriage Assembly	40
Micro Carriage Stop	43
Carriage Stop Assembly	44
Four Way Tool Post	46
Tailstock Assembly I	48
Tailstock Assembly II	50
Steady Rest Assembly	52
Follow Rest Assembly	54
Coolant & Work Light Assembly	56
Micro Carriage Stop	58
Other Parts	59
Electrical Cabinet	60
Wiring Diagram	61
Parts List for Lead Screw Protection Device	62
Safety Guard Cover	63
Parts List for Toolpost Protection device	64

Stand Assembly

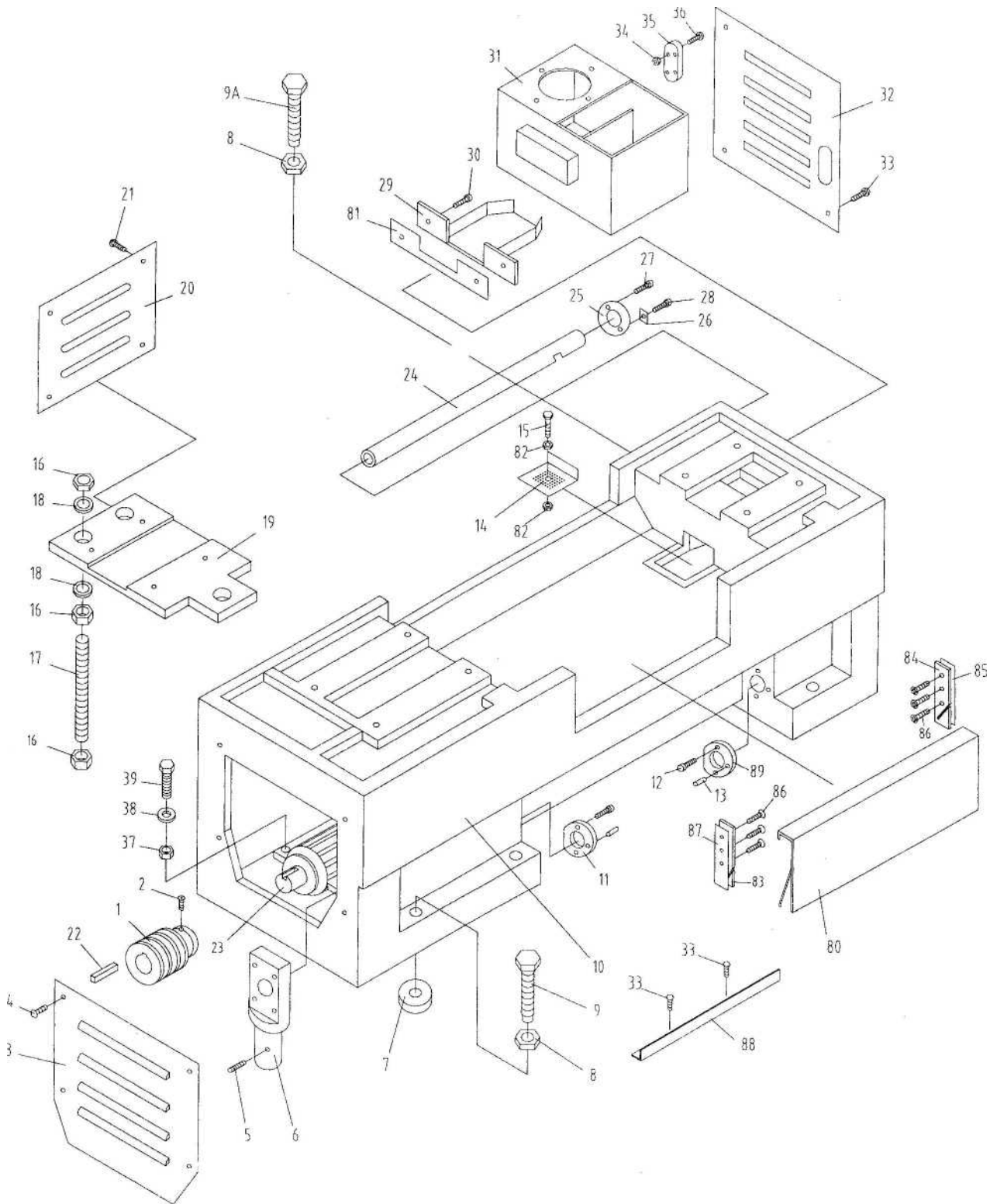

Stand Assembly

No.	Part No.	Description	Size	Qty.
1	ZX-01101A	Pulley		1
	GH2280ZX-01101	Pulley (for 2280ZX)		1
2	ZX-S2	Cylindrical End Set Screw	M8x16	1
3	ZX-01734	Cover		1
	ML-2080-01701	Cover (for 2280ZX)		1
4	ZX-S4	Cross Head Screw	M6x14	4
5	ZX-S2	Cylindrical End Set Screw	M8x16	1
6	ZX-01701	Pedal Rod Support		1
	ML-2080-01703	Pedal Rod Support (for 2280ZX)		1
7	ZX-01715	Lining		6
8	TS-1540231	Hex Nut	M24-2	6
9	ZX-01712	Hex Cap Bolt		3
9A	ZX-01713	Hex Cap Bolt		3
10	ZX-01102A	Bed Stand (for 40" models, serial #010611ZX349 and lower)		1
	ZX-01102AN	New Bed Stand (for 40" models, serial # 010618ZX350 and higher)		1
	ZX-01102B	Bed Stand (for 60" models, serial # 010611ZX349 and lower)		1
	ZX-01102BN	New Bed Stand (for 60" models, serial # 010618ZX350 and higher)		1
	ZX-01102C	Bed Stand (for 1880ZX, serial # 010611ZX349 and lower)		1
	ZX-01102CN	New Bed Stand (for 1880ZX, serial # 010618ZX350 and higher)		1
	GH2280ZX-01102	Bed Stand (for 2280ZX)		1
11	ZX-01703	Fixed Support		1
12	TS-150341	Socket Head Cap Screw	M6x14	4
13	ZX-S13	Taper Pin	5x20	2
14	ZX-01705	Water Leaking Chip Guard		1
15	ZX-S15A	Cross Head Screw	M5x20	4
16	TS-1540121	Hex Nut	M20	9
17	ZX-01702	Bolt		3
	ML-2080-01704	Bolt (for 2280ZX)		3
18	TS-1550111	Flat Washer	M20	6
19	ZX-01122A	Motor Mounting Plate (for 14" models)		1
	ZX-01122B	Motor Mounting Plate (for 16"/18" models)		1
	ML-2080-01122	Motor Mounting Plate (for 22" model)		1
20	ZX-01726	Cover		1
	GH2280ZX-01701	Cover		1
21	ZX-S4	Cross Head Screw	M6x14	4
22	ZX-S22	Key	10x8x70	1
23	ZX-S23BC	Main Motor (for 22" model)	10 HP, 6P, 3Ph	1
	ZX-S23A	Main Motor (for 14" models)	7.5HP, 4P, 3Ph	1
	ZX-S23B	Main Motor (for 16"/18" models)	7.5HP, 6P, 3Ph	1
24	ZX-017609A	Wire Conduit (for 1440/1640/1840ZX)		1
	ZX-017609B	Wire Conduit (for 1460/1660/1860ZX)		1
	ZX-017609C	Wire Conduit (for 1880/2280ZX)		1
25	ZX-01708	Wire Conduit Support		1
26	ZX-01706	Locking Plate		1
27	ZX-S27	Cross Head Screw	M5x8	2
28	ZX-S15	Cross Head Screw	M4x6	1
29	ZX-01711	Water Reception Plate		1
30	ZX-S4	Cross Head Screw	M6x14	2
31	ZX-01510	Coolant Tank		1
32	ZX-01714	Cover		1
	ML-2080-01702	Cover (for 2280ZX)		1
33	ZX-S4	Cross Head Screw	M6x14	4
34	ZX-S34	Nut	M3	4
35	ZX-S35	Coolant Indicator		1
36	ZX-S36	Cross Head Screw	M3x20	4

Stand Assembly

No.	Part No.	Description	Size	Qty.
37	TS-1540072	Hex Nut	M10	4
38	TS-1550071	Flat Washer	M10	4
39	TS-1491041	Hex Cap Bolt	M10x30	4
80	ZX-01716A	Stand Front Cover (for 1440/1640/1840ZX)		1
	ZX-01716B	Stand Front Cover (for 1460/1660/1860ZX)		1
	ZX-01716C	Stand Front Cover (for 1880/2280ZX)		1
81	ZX-01501	Gasket		1
82	ZX-S82	Hex Nut	M5	2
83	ZX-01740	Left Tray		1
84	ZX-01741	Right Tray		1
85	ZX-01511	Gasket		2
86	ZX-S86	Cross Head Screw	M5x16	6
87	ZX-01512	Gasket		1
88	ZX-05753	Extending Plate		1
	JX21004	Terminal Board (not shown)		1
	18301	Junction Box (not shown)		1
	D97-4	Plastic Fitting (not shown)		1
89	ZX-01703A	Fixed Support (serial # 7090341 and higher)		1

Brake Assembly

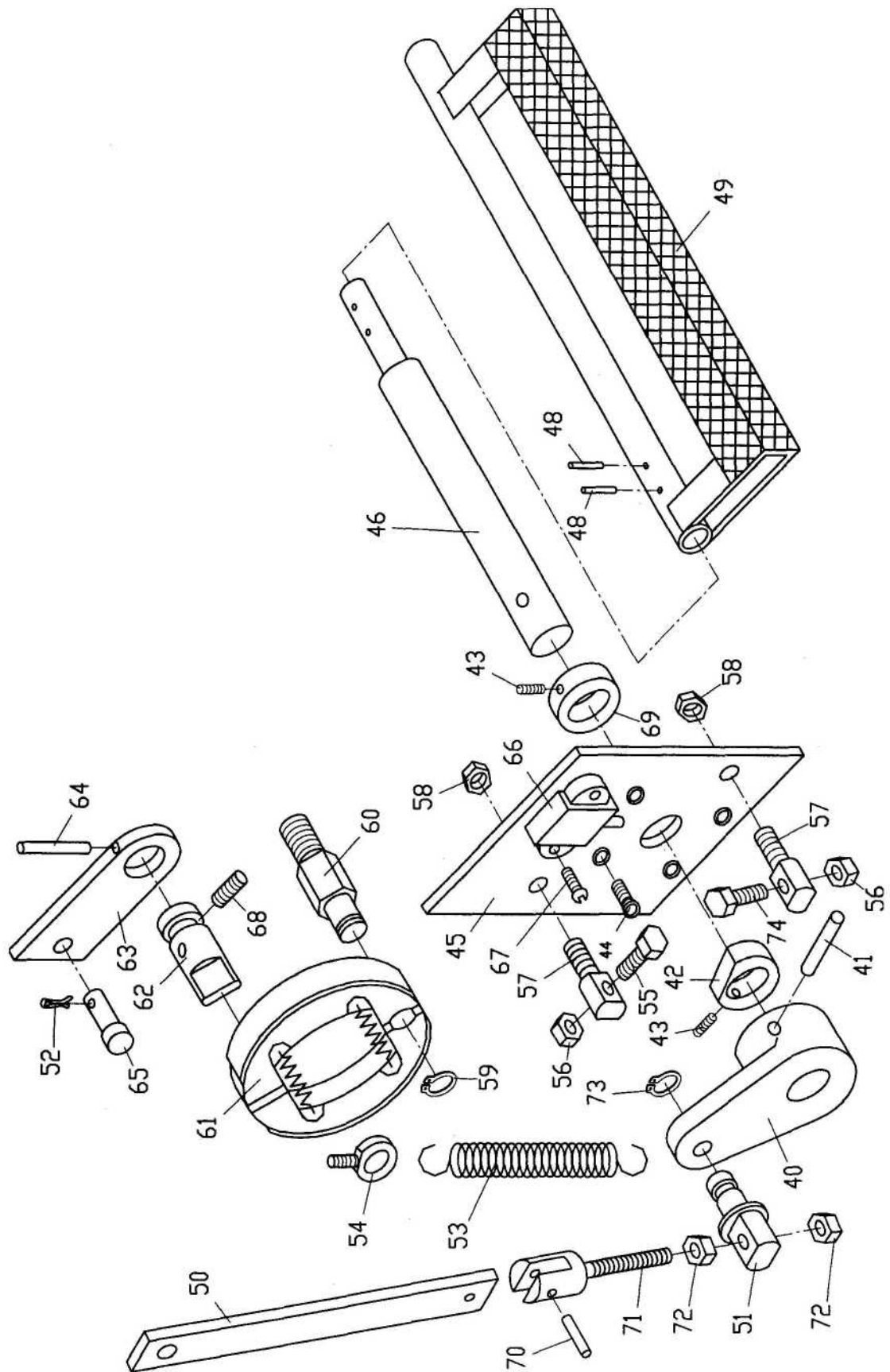

Brake Assembly

No.	Part No.	Description	Size	Qty.
40	ZX-22101	Fork		1
41	ZX-S41	Spring Pin	5x40	1
42	ZX-22703	Butt Nail Support		1
43	TS-1524021	Set Screw	M8x10	1
44	ZX-S44	Cross Head Screw	M5x20	4
45	ZX-22714	Positioning Plate		1
46	ZX-22704A	Driving Shaft-Longer		1
48	ZX-S48	Spring Pin	5x30	2
49	ZX-22712A	Pedal (for 1440/1640/1840ZX, serial # 7080340 and lower)		1
	ZX-22712AE	Pedal (for 1440/1640/1840ZX, serial # 7090341 and higher)		1
	ZX-22712B	Pedal (for 1460/1660/1860ZX, serial # 7080340 and lower)		1
	ZX-22712BE	Pedal (for 1460/1660/1860ZX, serial # 7090341 and higher)		1
	ZX-22712C	Pedal (for 1880/2280ZX, serial # 7080340 and lower)		1
	ZX-22712CE	Pedal (for 1880/2280ZX, serial # 7090341 and higher)		1
50	ZX-22710A	Draw Bar (for 14" models)		1
	ZX-22710B	Draw Bar (for 16" models)		1
	ZX-22710C	Draw Bar (for 18" models)		1
51	ZX-22706	Connecting Shaft		1
52	ZX-S52	Split Pin	2x20	2
53	ZX-S53	Tensile Spring	3.5x26x190	1
54	ZX-S54	Eyebolt	M8	1
55	TS-1490091	Hex Cap Bolt	M8x50	1
56	TS-1540061	Hex Nut	M8	1
57	ZX-22707A	Butt Rod Support		1
58	TS-1540072	Hex Nut	M10	1
59	ZX-S59	C-Clip	8	1
60	ZX-22701	Positioning Shaft		1
61	ZX-S61	Brake Shoe		1
62	ZX-22702	Brake Shaft		1
63	ZX-22708	Connecting Plate		1
64	ZX-S64	Elastic Pin	5x25	1
65	ZX-22709	Connecting Shaft		1
66	ZX-S66	Stroke Switch		1
67	ZX-S67	Screw	M4x25	2
68	ZX-S68	Cylindrical End Set Screw	M5x10	1
69	ZX-22711	Butt Nail Support		1
70	ZX-S70	Pin	5n6x20	1
71	ZX-22715	Adjust Bolt		1
72	TS-1540061	Hex Nut	M8	1
73	ZX-S73	C-Clip	12	2
74	ZX-S74	Hex Cap Bolt	M8x35	1
75	ZX-S75	Taper Pin	5x20	2

Bed Assembly

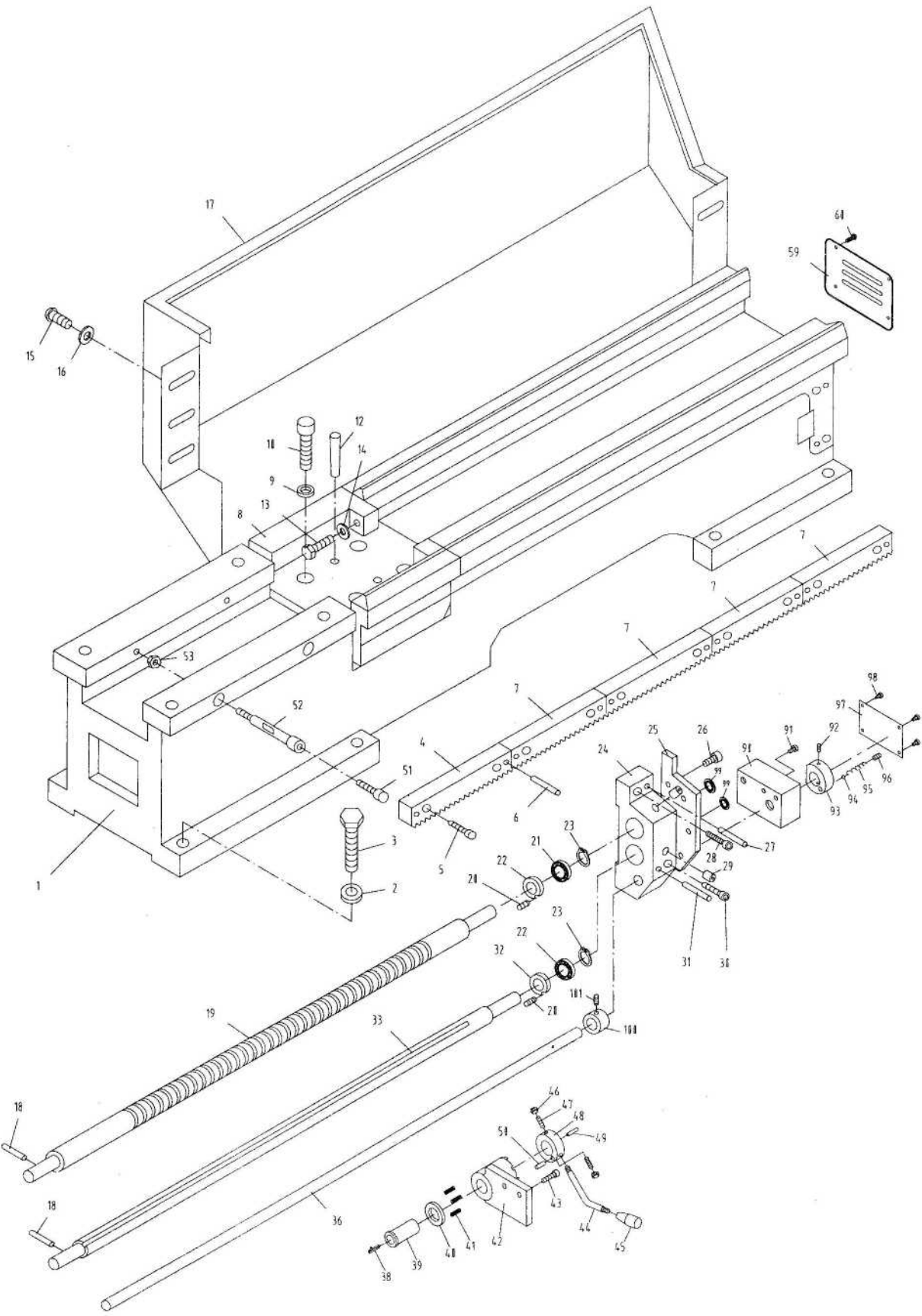

Bed Assembly

No.	Part No.	Description	Size	Qty.
1	ZX-01104A	Bed (for 1440/1640/1840ZX)		1
	ZX-01104B	Bed (for 1460/1660/1860ZX)		1
	ZX-01104C	Bed(for1880/2280ZX)		1
2	TS-1550101	Flat Washer	M16	8
3	ZX-B3	Hex Cap Bolt	M16x50	8
4	ZX-01706	Rack		1
5	TS-1505051	Hex Socket Cap Screw (for 1440/1640/1840ZX)	M 10x35	10
		Hex Socket Cap Screw (for 1460/1660/1860ZX)	M 10x35	14
		Hex Socket Cap Screw (for 1880/2280ZX)	M10x35	18
6	ZX-B6	Taper Pin (for 1440/1640/1840ZX)	8x50	10
		Taper Pin (for 1460/1660/1860ZX)	8x50	14
		Taper Pin (for 1880/2280ZX)	8x50	18
7	ZX-01706A	Rack (for 1440/1640/1840ZX)		4
		Rack (for 1460/1660/1860ZX)		6
		Rack (for 1880/2280ZX)		8
8	ZX-01112	Saddle		1
9	TS-1551081	Lock Washer	M12	4
10	TS-1506091	Hex Socket Cap Screw	M12x55	4
12	ZX-B12	Thread Taper Pin	12x70	2
13	TS-1491101	Hex Cap Bolt	M10x55	2
14	TS-1550071	Washer	M10	2
15	TS-1503021	Hex Socket Cap Screw	M6x10	6
16	TS-1550041	Washer	M6	6
17	ZX-01741A	Splash Guard (for 1440ZX)		1
	ZX-01741B	Splash Guard (for 1460ZX)		1
	ZX-01741C	Splash Guard (for 1640ZX)		1
	ZX-01741D	Splash Guard (for 1660ZX)		1
	ZX-01741E	Splash Guard (for 1840ZX)		1
	ZX-01741F	Splash Guard (for 1860ZX)		1
	ZX-01741G	Splash Guard (for 1880ZX)		1
	GH2280ZX-12701	Splash Guard (for 2280ZX)		1
18	ZX-B18	Shear Pin	5x35	2
19	ZX-01708A	Lead Screw (for 40" models, serial #010611ZX349 and lower)		1
	ZX-01708AN	New Lead Screw (for 40" models, serial # 010618ZX350 and higher)		1
	ZX-01708B	Lead Screw (for 60" models, serial #010611ZX349 and lower)		1
	ZX-01708BN	New Lead Screw (for 60" models, serial # 010618ZX350 and higher)		1
	ZX-01708C	Lead Screw (for 80" models, serial #010611ZX349 and lower)		1
	ZX-01708CN	New Lead Screw (for 80" models, serial #010618ZX350 and higher)		1
20	ZX-B20	Flat End Set Screw	M6x10	2
21	ZX-01109	Sleeve (serial # 010611ZX349 and lower)		1
	ZX-01109N	New Sleeve (serial # 010618ZX350 and higher)		1
22	ZX-1204	Double Row Spherical Ball Bearing	20x47x14	2
23	ZX-B23	C-Clip	20	2
24	ZX-01110	Bracket (serial # 010611ZX349 and lower)		1
	ZX-01110N	New Bracket (serial #010618ZX350 and higher)		1
25	ZX-01111	Cover		1
26	TS-1503041	Hex Socket Cap Screw	M6x16	4
27	ZX-B27	Taper Pin	6x60	1
28	TS-1505081	Socket Cap Screw	M10x50	1
29	ZX-B29	Oil Cup	10	2
30	TS-223991	Hex Socket Cap Screw	M10x100	1
31	ZX-B31	Taper Pin	6x100	1

Bed Assembly

No.	Part No.	Description	Size	Qty.
32	ZX-01108	Sleeve (serial # 010611ZX349 and lower)		1
	ZX-01108N	New Sleeve (serial # 010618ZX350 and higher)		1
33	ZX-01709A	Feed Rod (for 40" models, serial # 010611ZX349 and lower)		1
	ZX-01709AN	New Feed Rod (for 40" models, serial # 010618ZX350 and higher)		1
	ZX-01709B	Feed Rod (for 60" models, serial # 010611ZX349 and lower)		1
	ZX-01709BN	New Feed Rod (for 60" models, serial # 010618ZX350 and higher)		1
	ZX-01709C	Feed Rod (for 80" models, serial # 010611ZX349 and lower)		1
	ZX-01709CN	New Feed Rod (for 80" models, serial # 010618ZX350 and higher)		1
34	ZX-B34	Taper Pin	5x30	1
35	ZX-01107	Poking Block		1
36	ZX-01707A	Control Rod (for 1440/1640/1840ZX)		1
	ZX-01707B	Control Rod (for 1460/1660/1860ZX)		1
	ZX-01707C	Control Rod (for 1880/2280ZX)		1
37	TS-1540031	Nut	M5	1
38	ZX-06720	Small Shaft		2
39	ZX-06001C-3	Sleeve		1
40	ZX-06001C-2	Spacer		1
41	ZX-B41	Spring	1x75x25	3
42	ZX-06001C-1	Bracket		1
43	TS-1504031	Hex Socket Cap Screw	M8x16	2
44	ZX-B44	Lever		1
45	ZX-06001C-4	Long Lever Sleeve		1
46	ZX-B46	Hex Nut	M8	2
47	ZX-B47	Set Screw	M8x28	2
48	ZX-06001C-5	Direction Change Ring		1
49	ZX-B49	Pin	8n6x20	1
50	ZX-B50	Taper Pin	3x20	1
51	TS-1505081	Socket Cap Screw	M10x50	2
52	ZX-05741	Threaded Tube		2
53	TS-1540081	Hex Nut	M12	2
54	ZX-B54	Drum Switch		1
55	ZX-S27	Cross Head Screw	M5x8	5
56	ZX-01718	Rocker		1
57	ZX-B57	Pin	3x16	1
58	ZX-01716	Bracket		1
59	ZX-01715C	Cover		1
60	ZX-B60	Cross Recessed Pan Head Screw	M6x18	4
61	TS-1482031	Hex Cap Bolt	M6x16	2
62	ZX-B62	Pin	2x15	2
63	ZX-01719	Rocker		1
90	C0632A-01301E	Switch Box		1
91	ZX-B91E	Hex Socket Cap Screw	M8x20	4
92	ZX-B92E	Screw	M6x16	1
93	Co632A-01705E	Bushing		1
94	ZX-B94E	Steel Ball	6	1
95	ZX-B95E	Spring		1
96	ZX-B96E	Screw	M8x16	1
97	Co632A-01504E	Switch Box Cover		1
98	ZX-B98E	Hex Socket Cap Screw	M5x10	4
99	Co632A-01503E	Plug		2
100	ZX-01706E	Positioning Sleeve		1
101	ZX-B101E	Screw	M5x8	1

Headstock Assembly I

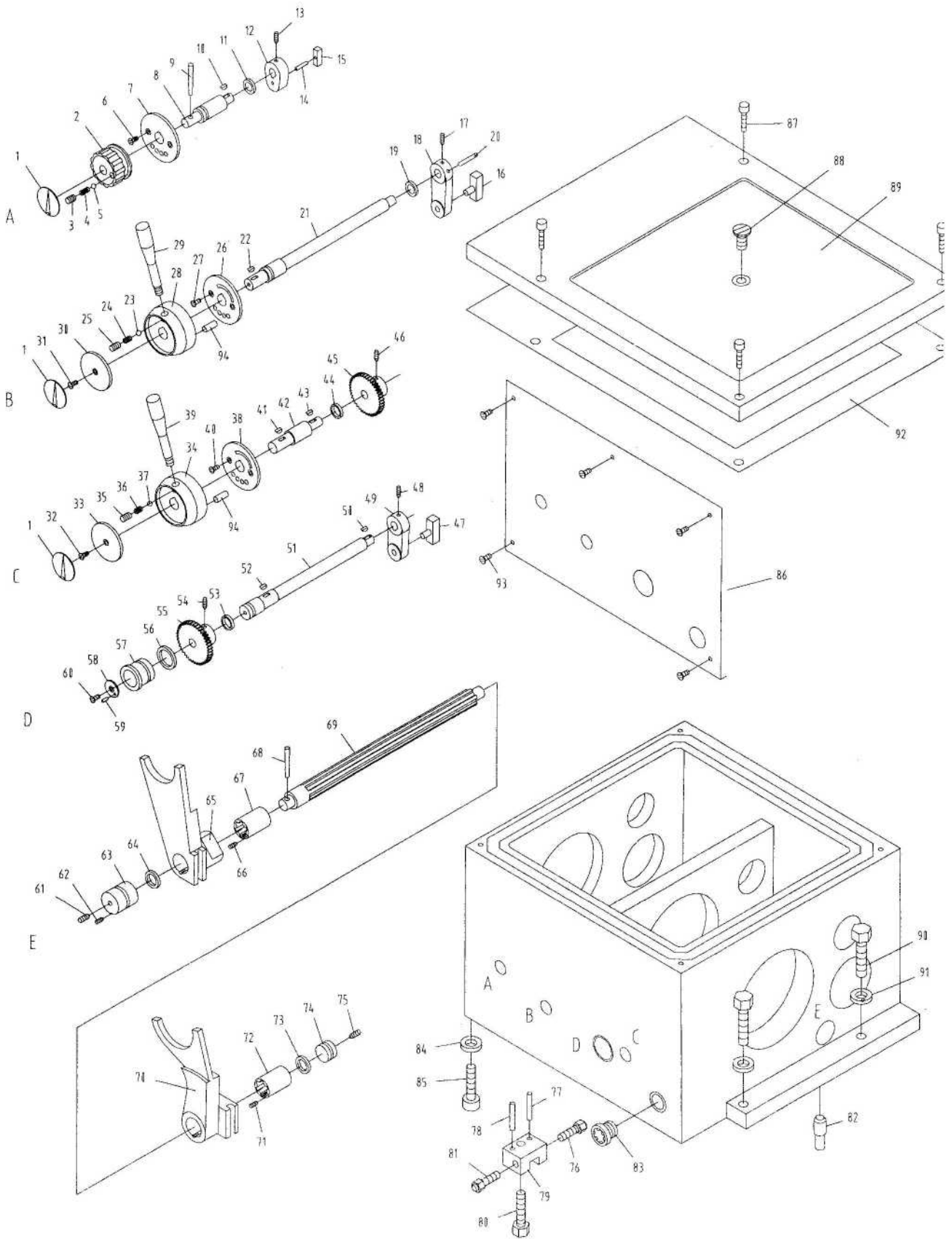

Headstock Assembly I

No.	Part No.	Description	Size	Qty.
1	ZX-02306	Round Sign Plate		3
2	ZX-02122	Positioning Handle		1
3	ZX-H3	Flat End Set Screw	M10x12	1
4	ZX-H4	Spring	YI-1x8x25	1
5	ZX-H5	Steel Ball	8	1
6	ZX-H6	Countersunk Head Screw	M5x12	2
7	ZX-02743	Positioning Disc		1
8	ZX-02738	Shaft		1
9	ZX-H9	Taper Pin	5x55	1
10	ZX-H10	Woodruff Key	4x16	1
11	ZX-H11	Ring Seal	25x2.4	1
12	ZX-02116	Crank		1
13	TS-1523051	Set Screw	M6x16	1
14	ZX-H14	Pin	5x6x28	1
15	ZX-02302	Poking Block		1
16	ZX-02738C	Pin Block		1
17	TS-1523051	Set Screw	M6x16	1
18	ZX-02114	Crank		1
19	ZX-H11	Ring Seal	25x2.4	1
20	ZX-H20	Pin	5x30	1
21	ZX-02734	Shaft		1
22	ZX-H10	Woodruff Key	4x16	1
23	ZX-H5	Steel Ball	8	1
24	ZX-H4	Spring	YI-1x8x25	1
25	ZX-H3	Flat End Set Screw	M10x12	1
26	ZX-02733	Left Positioning Disc		1
27	ZX-H6	Countersunk Head Screw	M5x12	2
28	ZX-02113	Left Lever Support		1
29	ZX-02741	Handle		1
30	ZX-02732	Cover		1
31	ZX-H6	Countersunk Head Screw	M5x12	1
32	ZX-H6	Countersunk Head Screw	M5x12	1
33	ZX-02732	Cover		1
34	ZX-02119	Right Lever Support		1
35	ZX-H3	Flat End Set Screw	M10x12	1
36	ZX-H4	Spring	YI-1x8x25	1
37	ZX-H5	Steel Ball	8	1
38	ZX-02728	Right Positioning Disc		1
39	ZX-02741	Handle		1
40	ZX-H6	Countersunk Head Screw	M5x12	2
41	ZX-H10	Woodruff Key	4x16	1
42	ZX-02727	Shaft		1
43	ZX-H10	Half Circle Key	4x16	1
44	ZX-H11	Ring Seal	25x2.4	1
45	ZX-02730	Gear	1.5m36T	1
46	TS-1523051	Set Screw	M6x16	1
47	ZX-02738C	Pin Block		1
48	TS-1523051	Set Screw	M6x16	1
49	ZX-02111	Crank		1
50	ZX-H10	Woodruff Key	4x16	1
51	ZX-02731/1	Control Shaft		1
52	ZX-H10	Woodruff Key	4x16	1
53	ZX-H11	Ring Seal	25x2.4	1
54	ZX-H54	Taper End Set Screw	M6x16	1
55	ZX-02732/2	Gear	1.5m36T	1
56	ZX-H56	Ring Seal	40x3.1	1

Headstock Assembly I

No.	Part No.	Description	Size	Qty.
57	ZX-02110	Bushing		1
58	ZX-02729	Cover		1
59	ZX-H59	Pin	3n6x10	1
60	ZX-H6	Countersunk Head Screw	M5x12	1
61	ZX-H61	Countersunk Head Screw	M8x12	1
62	ZX-H62	Flat End Set Screw	M8x12	1
63	ZX-02115	Bearing Support		1
64	ZX-H64	Ring Seal	40x3.1	1
65	ZX-02115	Left Fork		1
66	ZX-H66	Flat End Set Screw	M6x10	1
67	ZX-02120A/2	Bushing		1
68	ZX-H68	Taper Pin	6x35	1
69	ZX-02736	Control Shaft		1
70	ZX-02112	Right Fork		1
71	ZX-H66	Flat End Set Screw	M6x10	1
72	ZX-02120A/2	Bushing		1
73	ZX-H73	Ring Seal	30x3.1	1
74	ZX-02735	Blocking Piece		1
75	ZX-H61	Countersunk Head Screw	M8x12	1
76	ZX-02744	Adjusting Screw		1
77	ZX-H77	Taper Pin	8x40	1
78	ZX-H77	Taper Pin	8x40	1
79	ZX-92124	Adjusting Block		1
80	ZX-H80	Hex Cap Bolt	M12x50	1
81	ZX-02744	Adjusting Screw		1
82	ZX-02736C	Positioning Pin		1
83	ZX-H83	Oil Sight Glass		1
84	ZX-H84	Washer	A16	2
85	ZX-H85	Hex Socket Cap Screw	M16x50	2
86	ZX-02301A	Label (for 1440ZX)		1
	ZX-02301B	Label (for 1460ZX)		1
	ZX-02301C	Label (for 1640ZX)		1
	ZX-02301D	Label (for 1660ZX)		1
	ZX-02301E	Label (for 1840ZX)		1
	ZX-02301F	Label (for 1860ZX)		1
	ZX-02301G	Label (for 1880ZX)		1
		GH2280ZX-02301m	Label (for 2280ZX)	1
87	TS-1504071	Hex Socket Cap Screw	M8x35	4
88	ZX-H88	Countersunk Head Screw	M16x25	1
89	ZX-02117	Top Cover		1
90	ZX-H90	Hex Cap Bolt		2
91	ZX-H91	Washer	A16	2
92	ZX-02505	Paper Gasket		1
93	TS-1531012	Slotted Pan Head Screw	M3x6	7
94	ZX-H94N	Pin	4n6x15	2

Headstock Assembly II

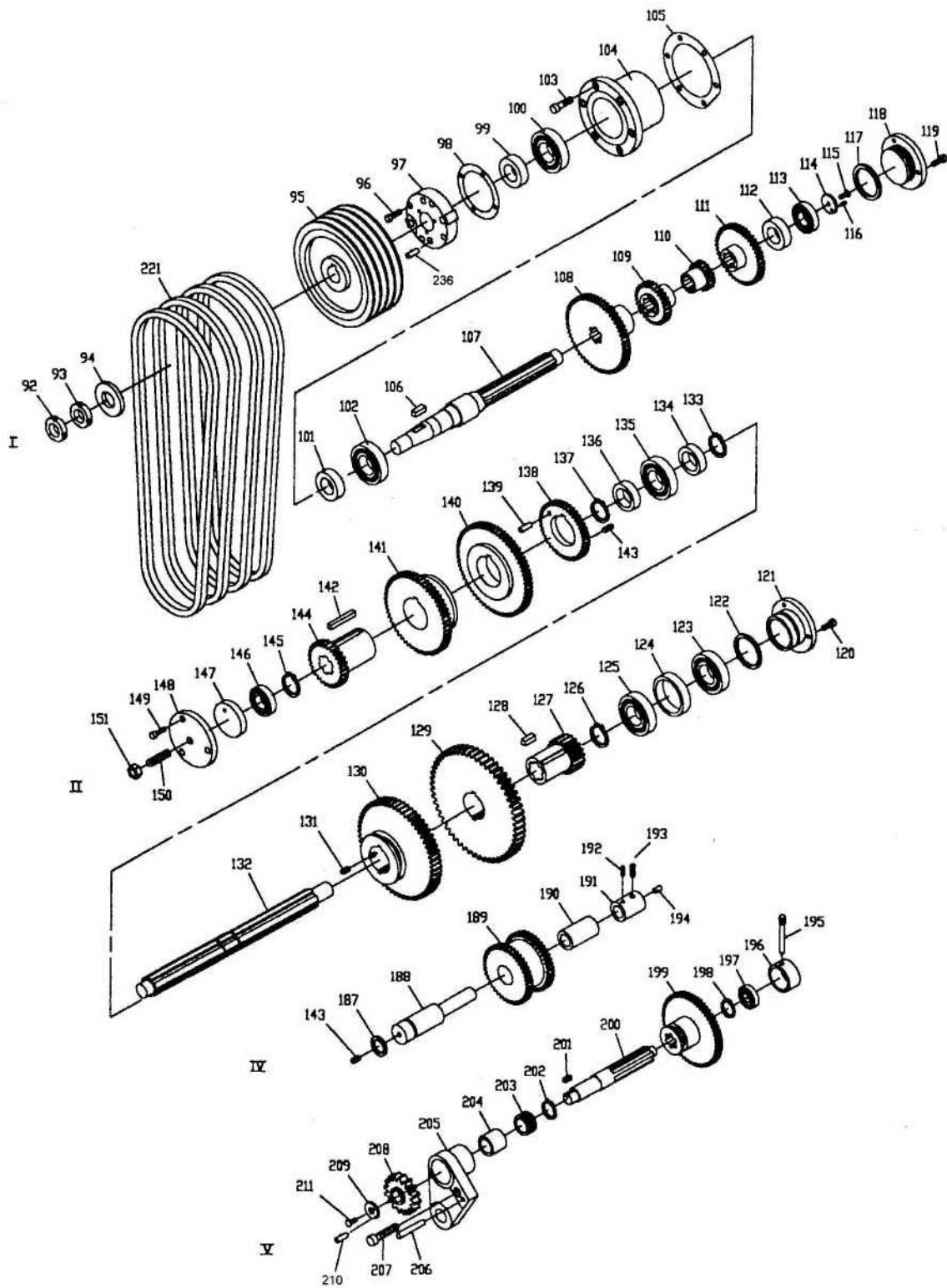

Headstock Assembly II

No.	Part No.	Description	Size	Qty.
95	ZX-02107	Pulley		1
96	TS-1503061	Socket Cap Screw	M6x25	4
97	ZX-02106	Bearing Cover		1
98	ZX-02506	Gasket		1
99	ZX-H99	Ring Seal	32x52	1
100	BB-6207/P5	Ball Bearing	35x72x17	1
101	ZX-H102	Sleeve	30x10	1
102	BB-6207/P5	Ball Bearing	35x72x17	1
103	TS-1504051	Socket Cap Screw	M8x25	6
104	ZX-02105	Bearing Support		1
105	ZX-02502	Gasket		1
106	ZX-H106	Flat Key	10x8x35	1
107	ZX-02709	Shaft		1
108	ZX-02754X	Gear (for 14" models)	2.5m52T	1
	ZX-02754X/6P	Gear (for 16"/18"/22" models)	2.5m61T	1
109	ZX-02753X	Gear (for 14" models)	2.5m28T	1
	ZX-02753X/6P	Gear (for 16"/18"/22" models)	2.5m32T	1
110	ZX-02752X	Gear	2.5m18T	1
111	ZX-02751X	Gear (for 14" models)	2.5m41T	1
	ZX-02751X/6P	Gear (for 16"/18"/22" models)	2.5m47T	1
112	ZX-H112	Sleeve		1
113	BB6305/P5	Ball Bearing	25x62x17	1
114	ZX-H114	Shaft End Lock Ring	32	1
115	ZX-H115	Countersunk Head Screw	M6x20	1
116	ZX-H59	Pin	3n6x10	1
117	ZX-H117	Ring Seal	60x3.1	1
118	ZX-02104	Blocking Flange		1
119	TS-1503041	Socket Cap Screw	M6x15	3
120	TS-1503041	Socket Cap Screw	M6x15	3
121	ZX-02103	Blocking Flange		1
122	ZX-H117	Ring Seal	60x3.1	1
123	BB-6305/P5	Ball Bearing	25x62x17	1
124	ZX-H124	Sleeve	62x6	1
125	BB-6305/P5	Ball Bearing	25x62x17	1
126	ZX-H126	Circle Clip For Shaft	35	1
127	ZX-02705	Gear	3m19T	1
128	ZX-H128	Flat Key	8x7x50	2
129	ZX-02706	Gear	3m67T	1
130	ZX-02707	Gear	3m59T	1
131	ZX-H62	Flat End Set Screw	M8x12	1
132	ZX-02708	Shaft		1
133	ZX-H133	C-Clip	35	1
134	ZX-H134	Sleeve	35x8	1
135	BB-6007/P5	Ball Bearing	35x62x14	1
136	ZX-H134	Sleeve	35x8	1
137	ZX-H133	C-Clip	35	1
138	ZX-02756	Gear (for 14" models)	2.5m42T	1
	ZX-02756/6P	Gear (for 16"/18"/22" models)	2.5m36T	1
139	ZX-H139	Pin	8n6x25	1
140	ZX-02757	Gear (for 14" models)	2.5m65T	1
	ZX-02757/6P	Gear (for 16"/18"/22" models)	2.5m65T	1
141	ZX-02758	Gear (for 14" models)	2.5m55T	1
	ZX-02758/6P	Gear (for 16"/18"/22" models)	2.5m51T	1
142	ZX-H142	Flat Key	10x6x60	2

Headstock Assembly II

No.	Part No.	Description	Size	Qty.
143	ZX-H143	Flat Head Set Screw	M8x12	2
144	ZX-02755X	Gear (for 14" models)	2.5m31T	1
	ZX-02755X/6P	Gear (for 16718722" models)	2.5m22T	1
145	ZX-H133	C-Clip	35	1
146	BB-6305	Ball Bearing	25x62x17	1
147	ZX-H147	Pushing Disc	62	1
148	ZX-02109C	Cover		1
149	TS-1503041	Socket Cap Screw	M6x15	3
150	ZX-H150	Set Screw	M12x65	1
151	ZX-H151	Hex Nut	M12	1
187	ZX-H187	Ring Seal	35x3.1	1
188	ZX-02714	Shaft		1
189	ZX-02716	Double Gear	2m48T	1
190	ZX-02303	Copper Sleeve		1
191	ZX-02734C	Positioning Sleeve		1
192	TS-1523031	Set Screw	M6x10	1
193	TS-1524041	Set Screw	M8x15	1
194	ZX-02733C	Blocking Piece		1
195	ZX-02718	Taper End Set Screw		1
196	ZX-02114C	Sleeve		1
197	BB-6203	Ball Bearing	17x40x12	1
198	ZX-H198	C-Clip	28	1
199	ZX-02717	Gear	2m65T	1
200	ZX-02715	Shaft		1
201	ZX-H201	Flat Key	5x5x1	1
202	ZX-H198	C-Clip	28	1
203	ZX-02722C	Sleeve		1
204	ZX-02301	Oil Bushing		1
205	ZX-08106A	Bracket (for Shaft V, Vb) (for 14"16" models)		1
	ZX-08106B	Bracket (for Shaft V, Vb) (for 18" models)		1
	GH2280ZX-08106	Bracket (for Shaft V, Vb, Vc) (for 22" model)		1
206	ZX-H77	Taper Pin	8x40	1
207	TS-1505031	Hex Socket Cap Screw	M10x25	1
208	TNMP-08706A(N)	Gear (for 14716722" models)	3.5m15T	1
	TNMP-08706B(N)	Gear (for 18" models)	4m15T	1
209	ZX-02724C	Washer		1
210	ZX-H59	Pin	3n6x10	1
211	ZX-H211	Countersunk Head Screw	M5x16	1
221	VB-A1931	V-Belt (for 14" models)	A-1931	4
	VB-A1956	V-Belt (for 16" models)	A-1956	4
	VB-A1981	V-Belt (for 18" models)	A-1981	4
	VB-A2159	V-Belt (for 22" model)	A-2159	4
233	ZX-02506	Paper Gasket		2
234	ZX-H234	Set Screw	M8x6	2
235	ZX-02743N	Clamping Round Nut		1
236	ZX-H236	Pin	8X30	2

Headstock Assembly III

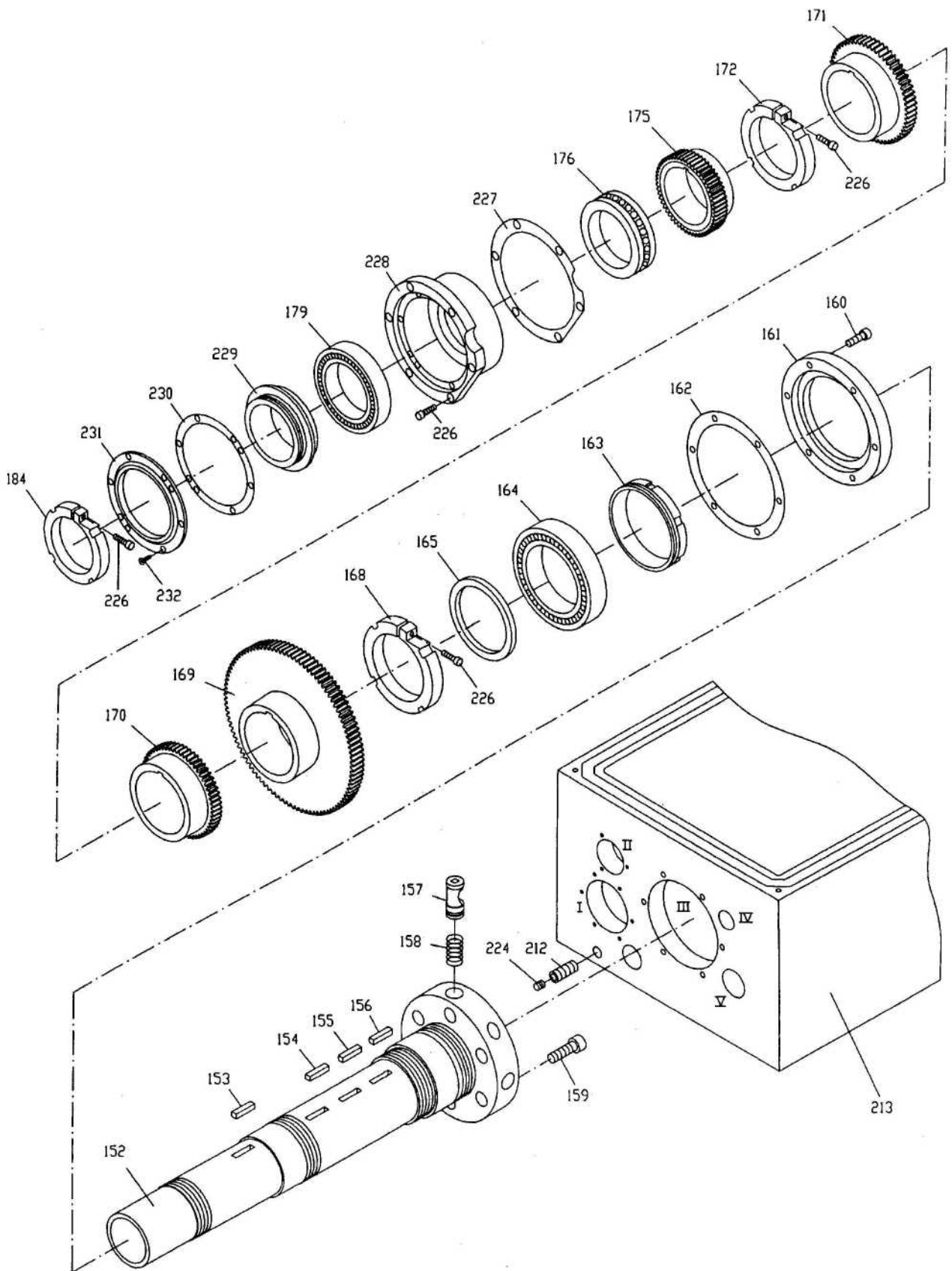

Headstock Assembly III

No.	Part No.	Description	Size	Qty.
152	ZX-02704	Spindle		1
153	ZX-H153	Flat Key	10x8x40	1
154	ZX-H154	Flat Key	10x8x50	1
155	ZX-H155	Flat Key	12x8x50	1
156	ZX-H156	Flat Key	14x9x50	1
157	ZX-02701	Cam Lock		6
158	ZX-H158	Spring	1x8x25	6
159	ZX-02703	Cam Positioning Screw		6
160	TS-1505041	Hex Socket Cap Screw	M10x28	6
161	ZX-02102	Bearing Front Cover		1
162	ZX-02501	Gasket		1
163	ZX-02702	Oil Splashing Ring		1
164	NN3024/P5	Taper Roller Bearing	120x180x46	1
165	ZX-02726	Lining		1
168	ZX-02725A	Round Nut w/Screw		1
169	ZX-02723	Gear	3m98T	1
170	ZX-02722	Gear	3m50T	1
171	ZX-02721	Gear	3m58T	1
172	ZX-02720A	Round Nut w/Screw		1
175	ZX-02710	Gear	2m65T	1
176	51120/P5	Thrust Bearing	100x135x25	1
179	BB-7020AC/P5	Angular Bearing	100x150x24	1
184	ZX-02713A	Round Nut w/Screw		1
212	ZX-H212	Drain Plug (14" models, serial # 001204ZX258 and lower)		1
	ZX-H212	Drain Plug (16" models, serial #010312ZX293 and lower, also includes serial # 010319ZX298 and 299)		1
	ZX-H212	Drain Plug (18" models, serial #010416ZX313 and lower)		1
	ZX-H212A	Drain Plug (14" models, serial # 010105ZX263 and higher)		1
	ZX-H212A	Drain Plug (16" models, serial #010319ZX294 and higher, except for serial # 010319ZX298 and 299)		1
	ZX-H212A	Drain Plug (18" models, serial # 010514ZX323 and higher)		1
	ZX-H212A	Drain Plug (22" model)		1
213	ZX-02101A	Headstock Casting (14" models, serial # 001204ZX258 and lower)		1
	ZX-02101AN	Headstock Casting (14" models, serial # 010105ZX263 and higher)		1
	ZX-01201B	Headstock Casting (16" models, serial # 010312ZX293 and lower, also includes serial # 110319ZX298 and 299)		1
	ZX-02101BN	Headstock Casting (16" models, serial #010319ZX294 and higher, except for serial # 010319ZX298 and 299)		1
	ZX-02101C	Headstock Casting (18" models, serial # 010416ZX313 and lower)		1
	ZX-02101CN	Headstock Casting (18" models, serial # 010514ZX323 and higher)		1
	GH2280ZX-02101	Headstock Casting (22" model)		1
224	ZX-G38-3A	Screw		1
226	ZX-H226	Hex Socket Cap Screw	M8x28	9
227	ZX-02502F	Gasket		1
228	ZX-02108F	Bearing Support		1
229	ZX-02711F	Sleeve		1
230	ZX-02510F	Gasket		1
231	ZX-02761F	Bearing Back Cover		1
232	ZX-H232	Screw	M5x10	6

Headstock Assembly IV

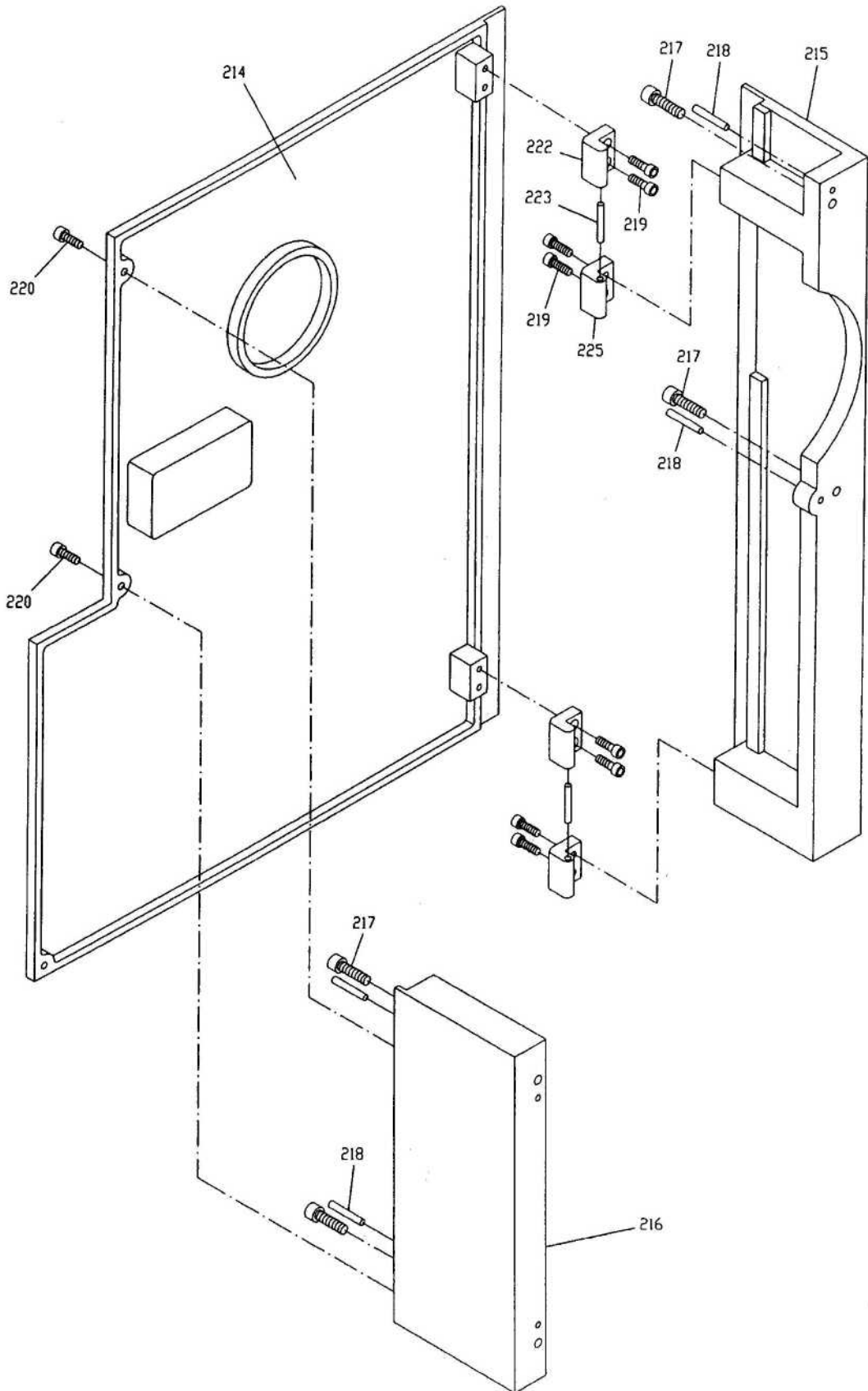

Headstock Assembly IV

No.	Part No.	Description	Size	Qty.
214	ZX-08302A	Back Cover (for 14" models)		1
	ZX-08302B	Back Cover (for 16" models)		1
	ZX-08302C	Back Cover (for 18" models)		1
	GH2280ZX-08301	Back Cover (for 22" model)		1
215	ZX-08114A	Rear Side Plate (for 14" models)		1
	ZX-08114B	Rear Side Plate (for 16" models)		1
	ZX-08114C	Rear Side Plate (for 18" models)		1
	GH2280ZX-08114	Rear Side Plate (for 22" model)		1
216	ZX-08113A	Front Side Plate (for 14" models)		1
	ZX-08113B	Front Side Plate (for 16" models)		1
	ZX-08113C	Front Side Plate (for 18" models)		1
	GH2280ZX-08113	Front Side Plate (for 22" model)		1
217	TS-1504051	Socket Cap Screw	M8x25	4
218	ZX-H218	Taper Pin	6x25	4
219	TS-1503051	Socket Cap Screw	M6x20	8
220	TS-1514021	Socket Cap Screw	M6x15	3
222	ZX-08712	Upper Hinge		2
223	ZX-H223	Pin	6n6x40	2
225	ZX-08711	Lower Hinge		2

Change Gear Box Assembly I

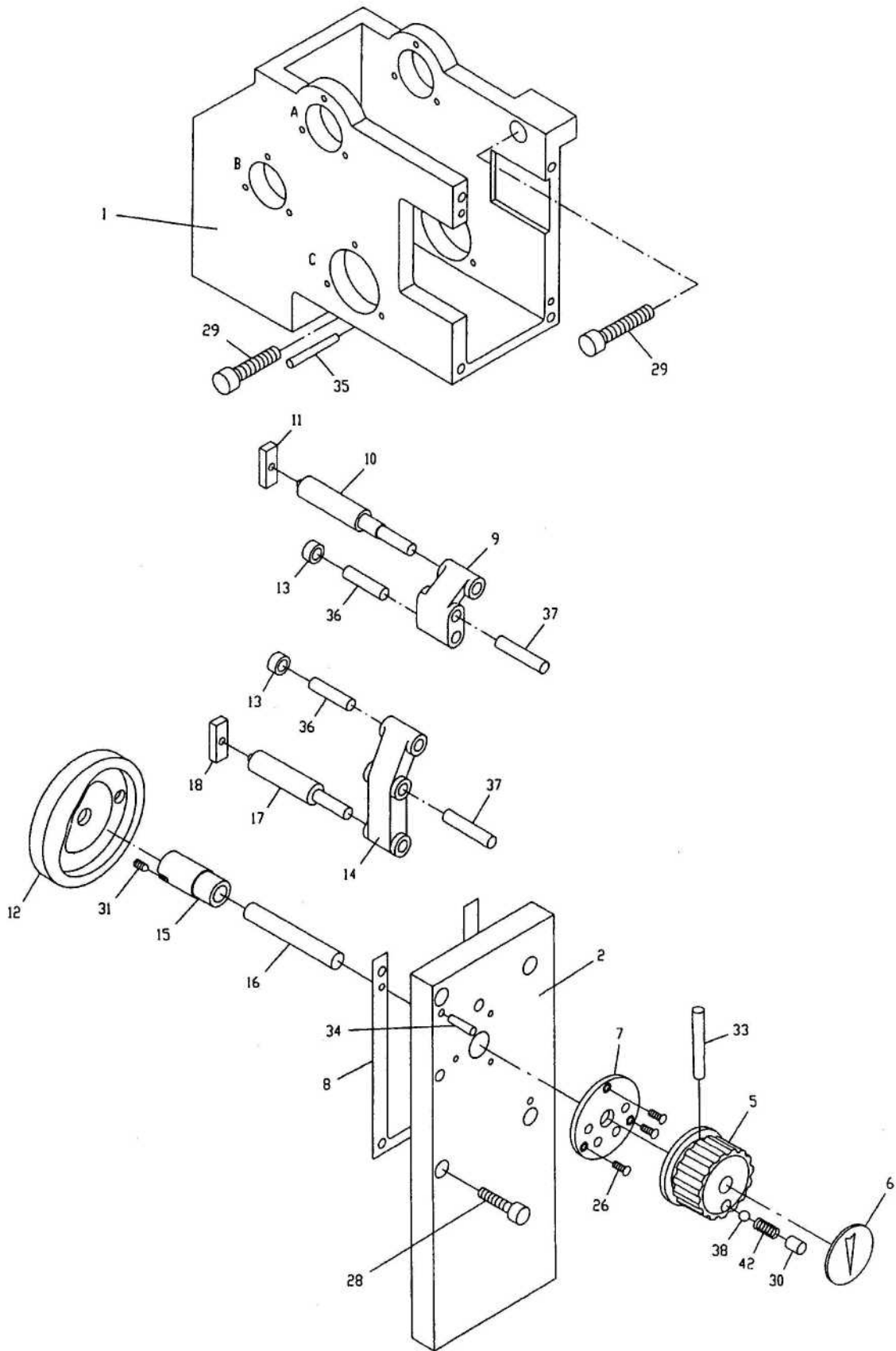

Change Gear Box Assembly I

No.	Part No.	Description	Size	Qty.
1	ZX-08101	Change Gear Box Casting		1
2	ZX-08108	Front Cover		1
5	ZX-05104C	Hand Wheel		1
6	ZX-05301C	Sign Plate		1
7	ZX-08708	Positioning Disc		1
8	ZX-08505	Gasket		1
9	ZX-08111	Crank		1
10	ZX-08705	Connecting Rod		1
11	ZX-08304	Sliding Block		1
12	ZX-05103C	Cam		1
13	ZX-05702C	Roller		2
14	ZX-08109	Crank		1
15	ZX-08110	Bushing		1
16	ZX-08704	Rotating Shaft		1
17	ZX-08703	Connecting Rod		1
18	ZX-08304	Sliding Block		1
26	ZX-C26	Cross Head Screw	M4x12	3
28	TS-1504051	Socket Cap Screw	M8x25	4
29	TS-1516051	Hex Socket Cap Screw	M10x40	2
30	TS-1525021	Set Screw	M10x12	1
31	ZX-C31	Flat Head Set Screw	M6x8	1
33	ZX-C33	Taper Pin	4x45	1
34	ZX-C34	Taper Pin	6x30	2
35	ZX-C35	Taper Pin	6x50	1
36	ZX-C36	Pin	10m6x40	2
37	ZX-C37	Pin	10m6x50	2
38	ZX-H5	Steel Ball	8	1
42	ZX-C42	Spring	1x8x30	1

Change Gear Box Assembly II

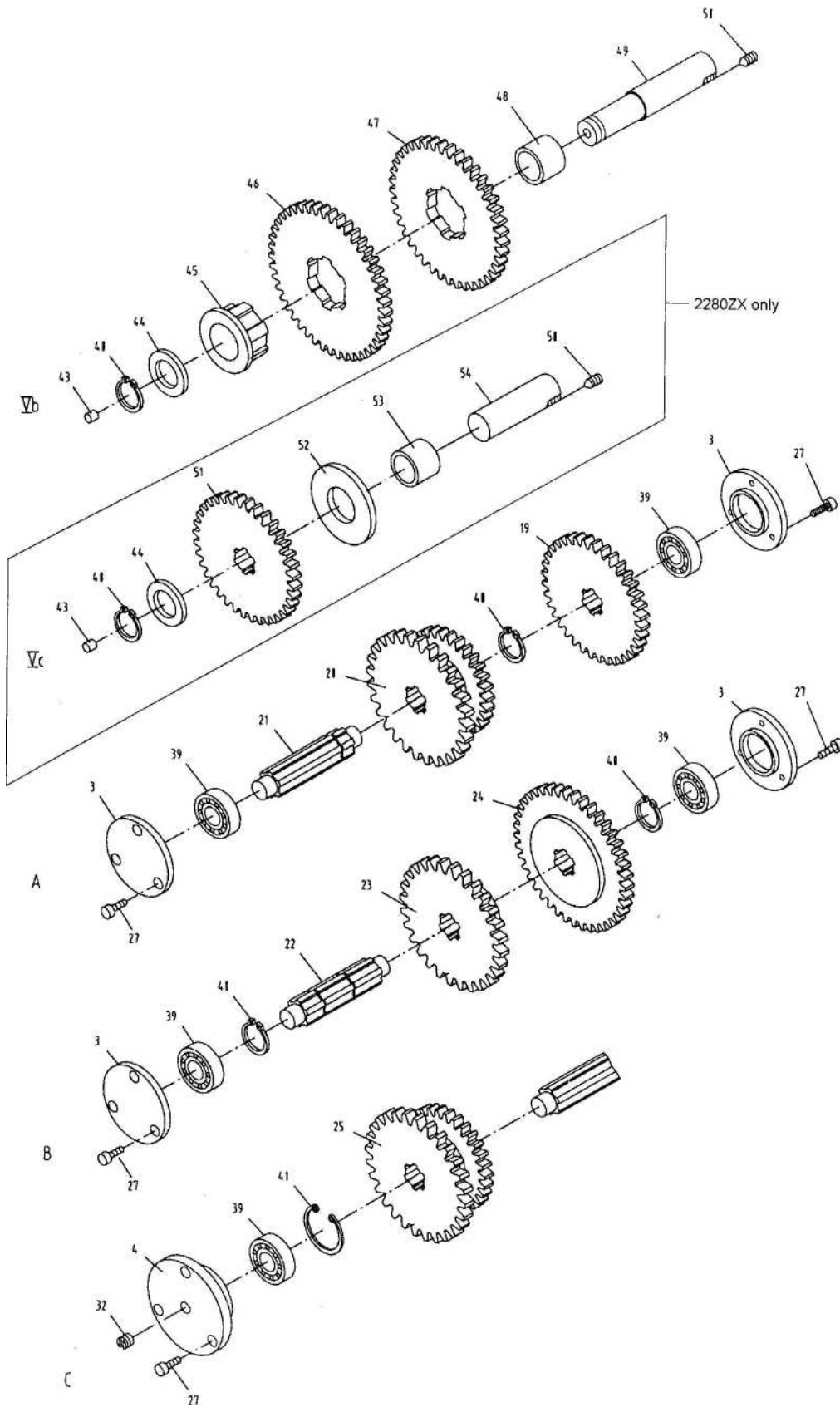

Change Gear Box Assembly II

No.	Part No.	Description	Size	Qty.
3	ZX-08104	End Cover		4
4	ZX-08103	Bearing Support		1
19	ZX-08107	Gear	3m36T	1
20	ZX-08105	Double Gear	3.75m28T/3m30T	1
21	ZX-08702	Shaft		1
22	ZX-08701	Shaft		1
23	ZX-08710	Gear	3.75m27T	1
24	ZX-08709	Gear	3m41T	1
25	ZX-08102	Double Gear	3.75m30T/3m29T	1
27	ZX-C27	Slotted Cheese Head Screw	M5x12	15
32	ZX-C32	Flat Head Set Screw	M10x12	1
39	BB-6203ZZ/P6	Ball Bearing	17x40x12	5
40	ZX-C40	C-Clip	25	4(5 for 22")
41	ZX-C41	C-Clip	40	1
43	ZX-C43	Oil Cup	8	1 (2 for 22")
44	TNMP08108	Washer		1 (2 for 22")
45	TNMP08102	Splined Sleeve		1
46	TNMP08504	Gear	3m45T	1
47	TNMP08501A	Gear (for 14716722" models)	3.5m35T	1
	TNMP08501B	Gear (for 18" models)	4m35T	1
48	ZX-05502C	Oil Bushing		1
49	ZX-08707	Shaft Vb		1
50	ZX-C50	Flat Head Set Screw	M8x10	1 (2 for 22")
51	GH2280ZX-08112	Gear (for 22" model)	3m30T	1
52	GH2280ZX-1052	Washer		1
53	GH2280ZX-1053	Oil Bushing		1
54	GH2280ZX-08707	Axis Vc (for 22" model)		1

Quick Change Gear Box I

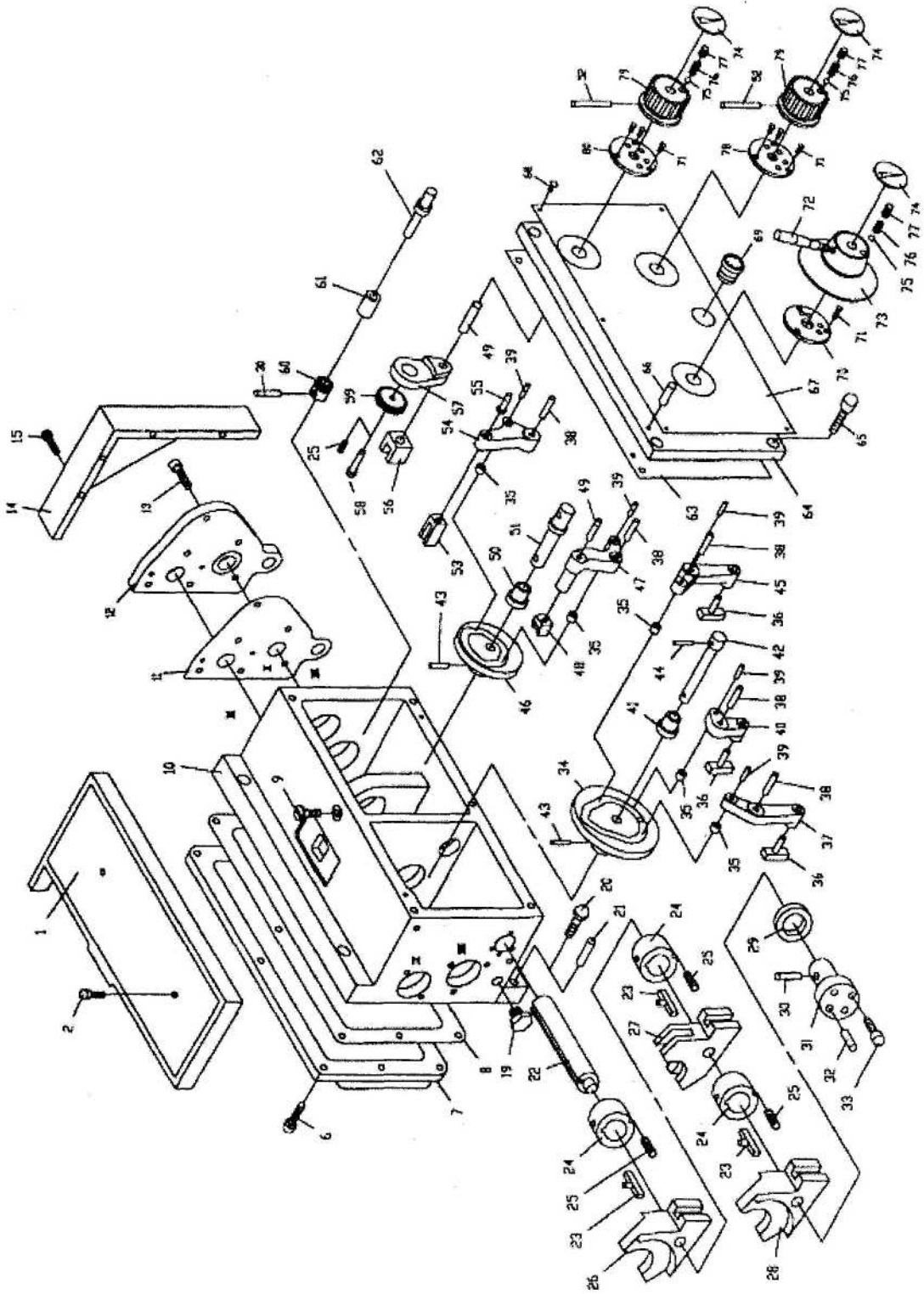

Quick Change Gear Box I

No.	Part No.	Description	Size	Qty.
1	ZX-05153A	Upper Cover		1
2	TS-1514051	Hex Socket Cap Screw	M6x30	2
6	TS-1515011	Hex Socket Cap Screw	M8x16	10
7	ZX-05109	Rear Cover		1
8	ZX-05502	Gasket		1
9	ZX-Q09	Countersunk Head Screw	M10x18	1
10	ZX-05101	Feedbox Casting		1
11	ZX-05501	Gasket		1
12	ZX-05108	Flange		1
13	TS-1515011	Hex Socket Cap Screw	M8x16	6
14	ZX-05151	Extending Plate		1
15	TS-1503131	Hex Socket Cap Screw	M6x60	4
19	ZX-Q19	Hex Cap Bolt	M10x1	1
20	TS-1491061	Hex Cap Bolt	M10x40	2
21	ZX-H68	Taper Pin	6x35	2
22	ZX-05738	Control Shaft		1
23	ZX-05739	Sliding Key		3
24	ZX-05128	Sliding Sleeve		3
25	ZX-Q25	Flat Head Set Screw	M5x8	4
26	ZX-05125	Right Fork		1
27	ZX-05126	Middle Fork		1
28	ZX-05127	Left Fork		1
29	ZX-Q29	Ring Seal	32x3.1	1
30	ZX-Q30	Taper Pin	4x25	2
31	ZX-05129	Cover		1
32	ZX-Q32	Pin	5n6x15	1
33	ZX-Q33	Cheese Head Screw	M5x16	3
34	ZX-05122	Cam		1
35	ZX-05728	Rolling Sleeve		5
36	ZX-05729	Poking Key		3
37	ZX-05123	Crank		1
38	ZX-Q38	Pin	8n6x32	5
39	ZX-Q39	Pin	6n6x20	5
40	ZX-05124	Crank		1
41	ZX-05111	Sleeve		1
42	ZX-05726	Lever Shaft		1
43	ZX-Q43	Taper Pin	4x32	2
44	ZX-Q44	Taper Pin	4x65	1
45	ZX-05121	Crank		1
46	ZX-05118	Cam		1
47	ZX-05120	Crank		1
48	ZX-05116	Fork		1
49	ZX-Q49	Pin	8n6x18	2
50	ZX-05117	Sleeve		1
51	ZX-05737	Lever Shaft		1
52	ZX-C33	Taper Pin	4x45	2
53	ZX-05115	Fork		1
54	ZX-05119	Crank		1
55	ZX-05735	Pin		1
56	ZX-05112	Fork		1
57	ZX-05113	Crank		1
58	ZX-05730	Small Shaft		1
59	ZX-05731	Big Gear	1m44T	1
60	ZX-05732	Small Gear	1m22T	1

Quick Change Gear Box I

No.	Part No.	Description	Size	Qty.
61	ZX-05114	Sleeve		1
62	ZX-05734	Lever Shaft		1
63	ZX-05503	Gasket		1
64	ZX-05110	Front Cover		1
65	TS-1516011	Hex Socket Cap Screw	M10x20	5
66	ZX-Q66	Taper Pin	5x35	6
67	ZX-05303A	Sign Plate		1
68	ZX-Q68	Cross Head Screw	M3x6	7
69	ZX-Q69	Oil Sight Glass	20	1
70	ZX-05727	Positioning Disc		1
71	ZX-Q71	Countersunk Head Screw	M4x12	9
72	ZX-05740	Lever		1
73	ZX-05130A	Lever Support		1
74	ZX-05301	Sign Disc		3
75	ZX-H5	Steel Ball	8	3
76	ZX-Q76	Compression Spring	YZ-1x8x25	3
77	ZX-H3	Flat End Set Screw	M10x12	3
78	ZX-05736	Positioning Disc		1
79	ZX-05140	Hand Wheel		2
80	ZX-05733	Positioning Disc		1

Quick Change Gear Box II

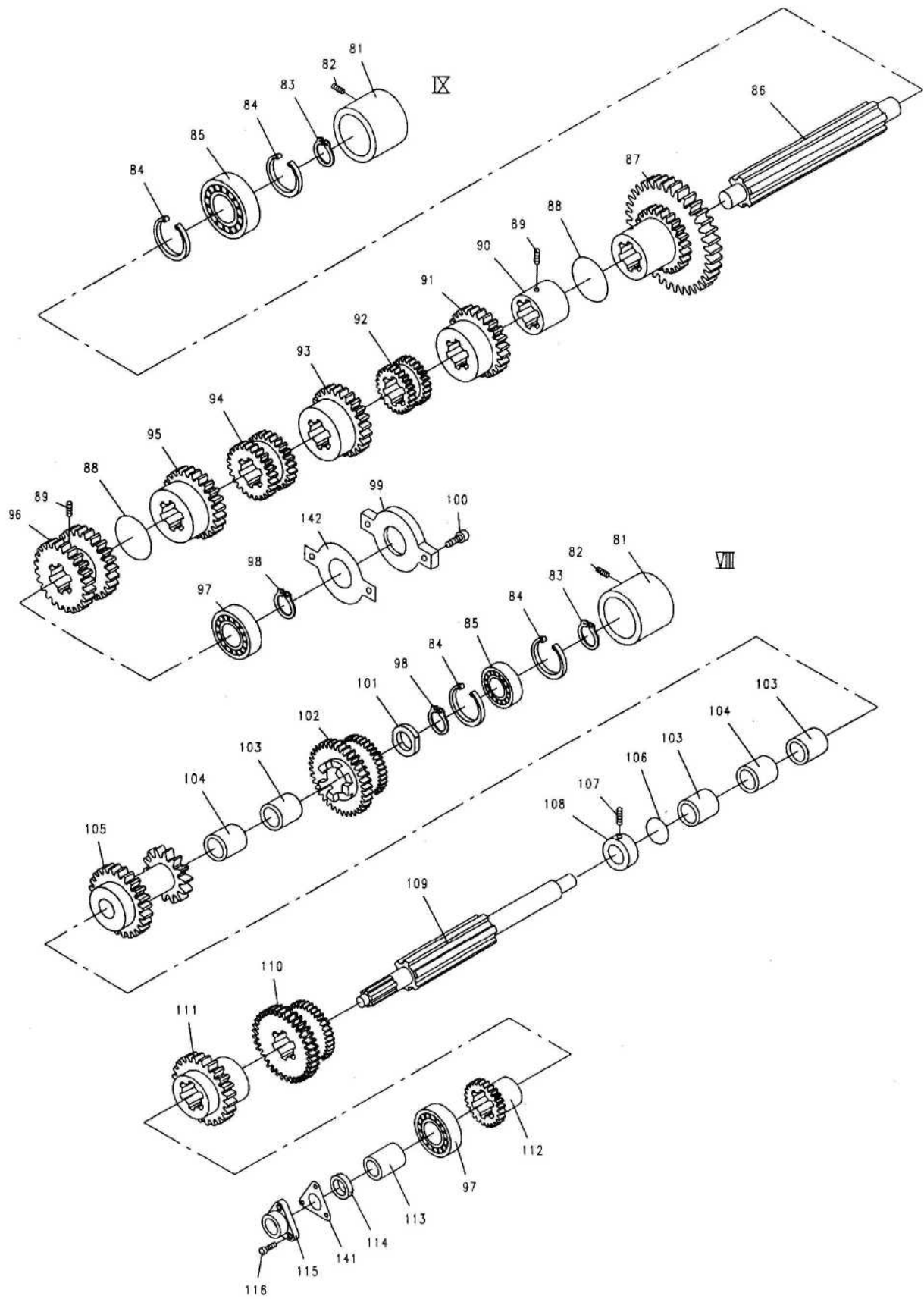

Quick Change Gear Box II

No.	Part No.	Description	Size	Qty.
81	ZX-05104	Middle Bearing Support		2
82	ZX-Q82	Taper End Set Screw	M10x16	2
83	ZX-B23	C-Clip	20	3
84	ZX-Q84	C-Clip	42	5
85	BB-6004	Single Row Radial Ball Bearing	20x42x12	5
86	ZX-05721	Shaft		1
87	ZX-05722	Double Gear	2m26T/2m52T	1
88	ZX-Q88	Iron Wire	1x190	2
89	TS-1524051	Set Screw	M8x20	2
90	ZX-05720	Positioning Sleeve		1
91	ZX-05719	Gear	2.25m28T	1
92	ZX-05718	Double Gear	2m26T/2m28T	1
93	ZX-05717	Gear	3.5m20T	1
94	ZX-05716	Double Gear	3.5m18T/3.5m19T	1
95	ZX-05715	Gear	3.25m22T	1
96	ZX-05714	Double Gear	3.25m24T/3.25m23T	1
97	BB-6205	Single Row Radial Ball Bearing	25x52x15	2
98	ZX-C40	C-Clip	25	3
99	ZX-05125	Shaft End Cover		1
100	TS-1515011	Hex Socket Cap Screw	M8x18	2
101	ZX-05704	Spacer		1
102	ZX-05705	Double Gear	2m52T/2m26T	1
103	ZX-05502C	Oil Bushing		3
104	ZX-05105	Sleeve		2
105	ZX-05707	Double Gear	2m39T/2m26T	1
106	ZX-Q106	Iron Wire	1x160	3
107	TS-1524031	Set Screw	M8x12	3
108	ZX-05714C	Fixed Bushing		1
109	ZX-05710	Shaft		1
110	ZX-05709	Double Gear	2m48T/2.25m42T	1
111	ZX-05711	Sliding Gear	3.5m24T	1
112	ZX-05712	Sliding Gear	3.25m24T	1
113	ZX-05713	Sleeve		1
114	ZX-G51-1	Spacer	32	1
115	ZX-05106	Bearing Support		1
116	TS-1515031	Hex Socket Cap Screw	M8x25	3
141	ZX-05504	Gasket		1
142	ZX-05505	Gasket		1

Quick Change Gear Box III

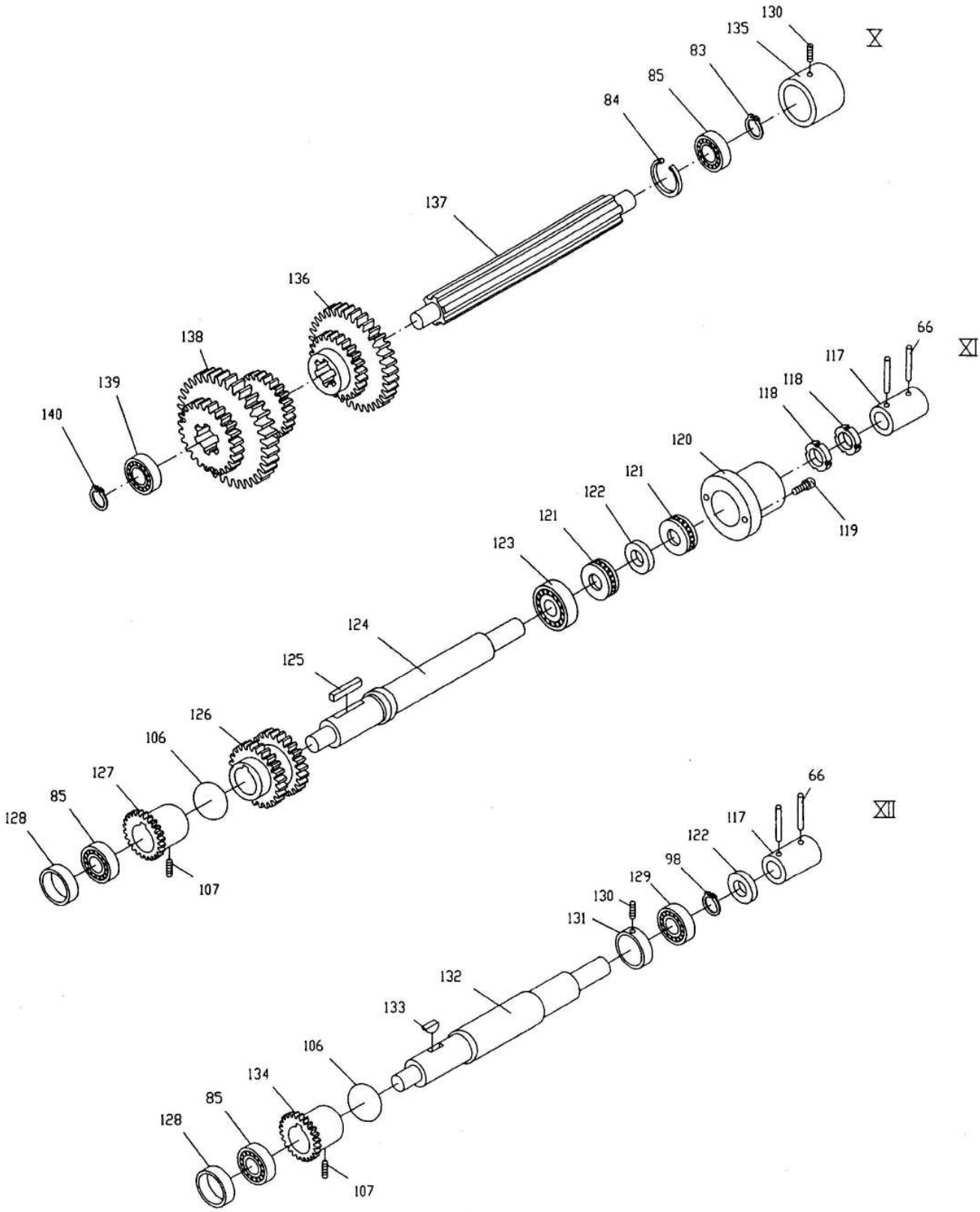

Quick Change Gear Box III

No.	Part No.	Description	Size	Qty.
66	ZX-Q66	Taper Pin	5x35	6
83	ZX-Q83	C-Clip	20	3
84	ZX-Q84	C-Clip	42	5
85	BB104	Single Row Radial Ball Bearing	20x42x12	5
98	ZX-Q98	C-Clip	25	3
106	ZX-Q106	Iron Wire	1x160	3
107	TS-1524031	Set Screw	M8x12	3
117	ZX-05113C	Shaft Coupling		2
118	ZX-Q118	Round Nut	M24x1.5	2
119	TS-1503021	Hex Socket Cap Screw	M6x10	2
120	ZX-05114	Cover		1
121	BB-51105	Thrust Bearing	25x42x11	2
122	ZX-Q122	Spacer	25	2
123	BB-6305	Ball Bearing	25x62x17	1
124	ZX-05725	Shaft		1
125	ZX-Q125	Key	8x7x50	1
126	ZX-05724	Double Gear	2.25m35T/2.25m36T	1
127	ZX-05723	Gear	2.5m36T	1
128	ZX-05107	Sleeve		2
129	BB-6005	Ball Bearing	25x47x12	1
130	TS-1525021	Set Screw	M10x12	2
131	ZX-05103	Bearing Support		1
132	ZX-05701	Shaft		1
133	ZX-Q133	Half Circle Key	6x22	1
134	ZX-05703	Gear	2.5m36T	1
135	ZX-05102	Bearing Support		1
136	ZX-05702	Double Gear	2.5m24T/2.25m35T	1
137	ZX-05708	Shaft		1
138	ZX-05706	Triple Gear	2m39T/2m52T/2m26T	1
139	BB-6203	Ball Bearing	17x40x12	1
140	ZX-Q140	C-Clip	17	1

Apron Assembly I

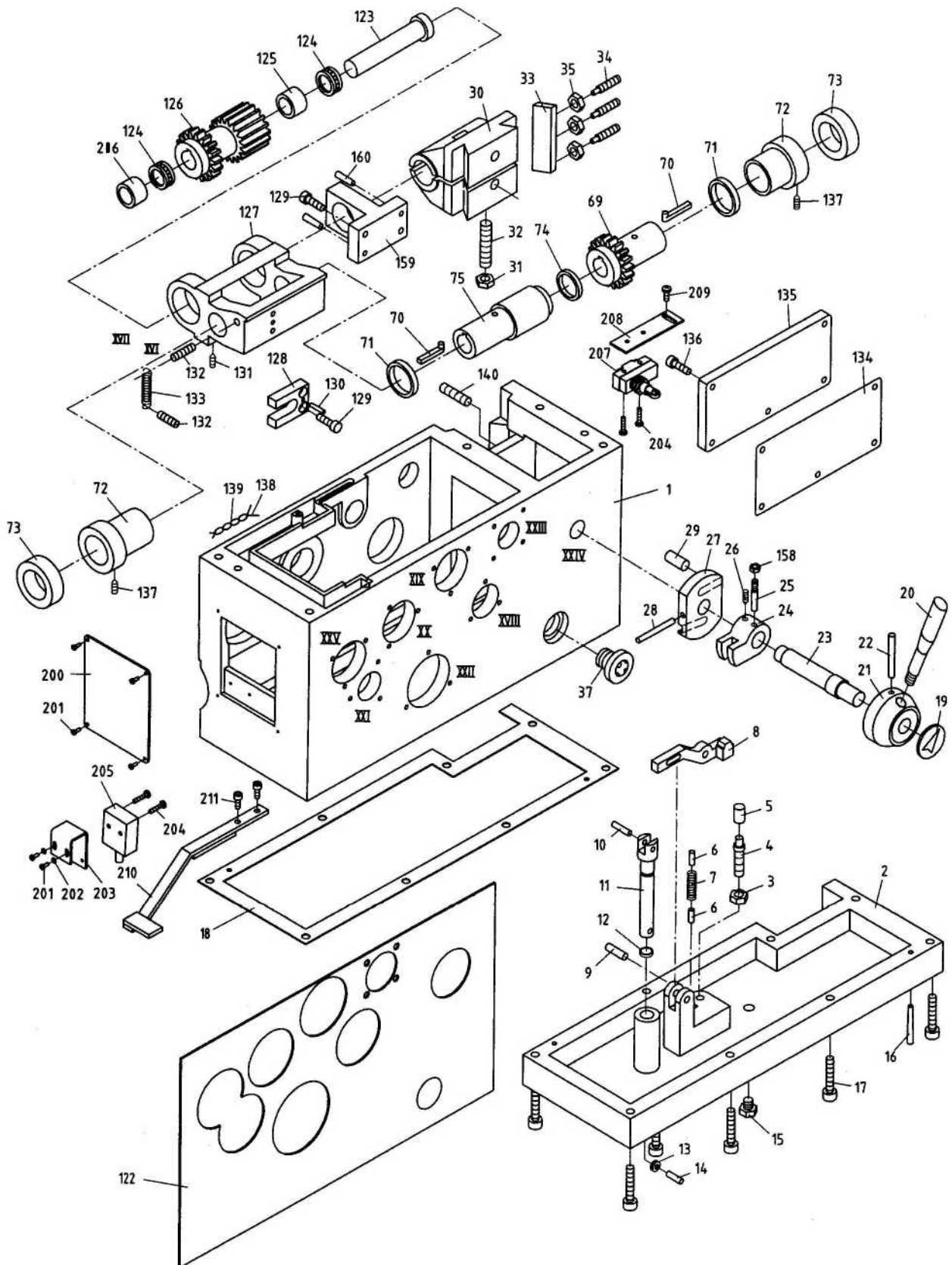

Apron Assembly I

No.	Part No.	Description	Size	Qty.
1	ZX-K06101	Apron Casting		1
2	ZX-K 06112	Bottom Cover		1
3	TS-1540072	Hex Nut	M10	1
4	GB71	Flat Head Set Screw	M10x45	1
5	TL06502	Cushion Cap		1
6	ZX-A06	Pin	6n6x16	2
7	ZX-A07	Tensile Spring	YI-1.2x9x50	1
8	ZX-K06719A	Lever		1
9	ZX-A09	Pin	8n6x30	1
10	ZX-A10	Pin	6n6x18	1
11	TL06701-A	Pushing Rod		1
12	ZX-A12	Oil Seal	15x2.4	1
13	BB60016	Ball Bearing	6x17x6	1
14	ZX-A06	Pin	6n6x12	1
15	ZX-A15	Drain Plug	Z 1/4"	1
16	ZX-B34	Taper Pin	5x30	2
17	GB70	Hex Socket Cap Screw	M8x45	8
18	ZX-K06501	Gasket		1
19	TL06307	Sign Plate		1
20	TL06716	Lever		1
21	C6132-06122	Lever Support		1
22	ZX-B27	Taper Pin	6x60	1
23	ZX-K06706	Half Nut Shaft		1
24	TL06111Ab	Positioning Block		1
25	ZX-A25	Thread Tail Taper Pin	6x25	1
26	TS-1523031	Set Screw	M6x10	1
27	C6136-06733	Half Nut Control Plate		1
28	ZX-A28	Taper Pin	6x55	1
29	C6136-06732	Pin		2
30	ZX-06302	Half Nut		1
31	TS-1540072	Hex Nut	M10	1
32	ZX-A32	Cylindrical End Set Screw	M10x55	1
33	C6136-06121	Gib		1
34	ZX-06A731	Cylindrical End Set Screw		3
35	TS-1540061	Hex Nut	M8	3
36	ZX-A36	Set Screw	M8x32	1X
37	ZX-A37	Oil Sight Glass	20	1
69	TL06727N	Gear	2m25T	1
70	TL06728	Sliding Key		2
71	ZX-06121A	Spacer		2
72	TL06304N	Worm bracket		2
73	ZX-A73	Ring Seal For Rotating	3x55	2

Apron Assembly I

No.	Part No.	Description	Size	Qty.
74	ZBJ2202	"O" ring	M33-B26503270	1
75	TL06729A	Sleeve		1
122	ZX-K06302	Sign Plate		1
123	TL06730	Shaft		1
124	BB-51104	Thrust Bearing	25 x 35 x 10	2
125	TL06305	Sleeve		1
126	ZX-06726A	Worm		1
127	ZX-06122A	Worm Support		1
128	TL06720	Control Plate		1
129	TS-1514031	Hex Socket Cap Screw	M6x16	2
130	ZX-A130	Taper Pin	4x20	1
131	TS-1524031	Set Screw	M8x12	2
132	ZX-A132	Screw	M8x25	2
133	ZX-A133	Cylindrical Tensile Spring	L1-1.6x10x58	1
134	TL06503	Gasket		1
135	TL06114	Back Cover		1
136	TS-1514011	Hex Socket Cap Screw	M6x12	5
137	ZX-A137	Set Screw	M8x30	2
138	ZX-A138	Iron Wire	1x50	2
139	ZX-A139	Oil Conducting Cord	3x100	2
140	ZX-A140	Screw	M10x40	1
158	TS-1540041	Hex Nut	M6	1
159	ZX-06124A	Bracket		1
160	ZX-A160	Pin	5x16	2
200	ZX-K06721	Cover		1
201	ZX-A201E	Cross head screw	M4x8	6
202	GB97. 1	Washer	3	2
203	ZX-K06720	Bracket		1
204	ZX-A204E	Head screw	M3x22	4
205	LXW5-11N1	Limit switch		1
206	TL06120	Sleeve		1
207	LXW5-11Q1	Limit switch		1
208	ZX-K18710	Cover		1
209	GB818	Cross head screw	M5x10	2
210	ZX-K06726	Sleeve		1
211	GB70	Hex Socket Cap Screw	M5x10	2

Apron Assembly II

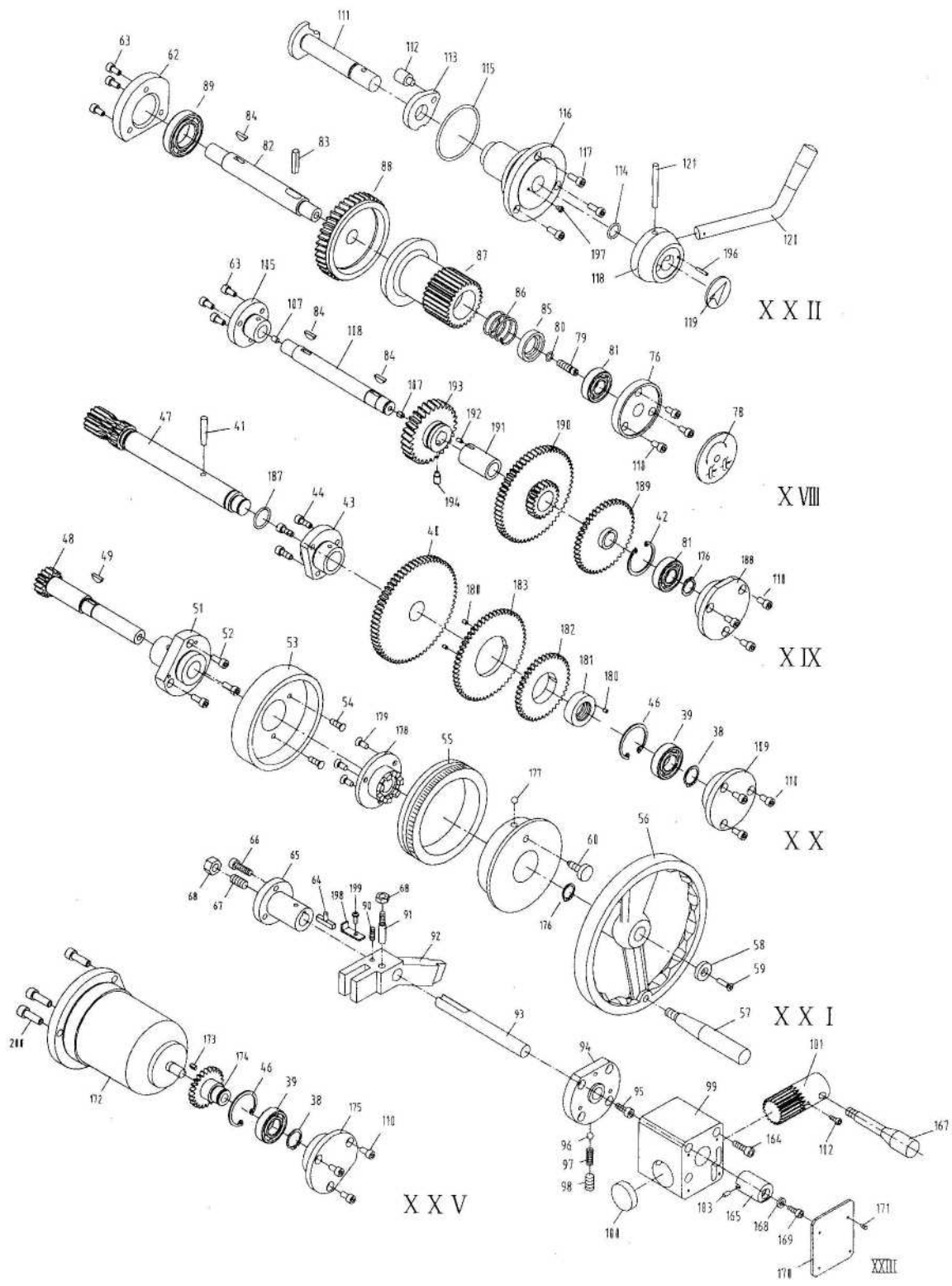

Apron Assembly II

No.	Part No.	Description	Size	Qty.
38	GB894.1	C-Clip	20	2
39	6104	Ball Bearing	20x42x12	2
40	TL06705	Gear	2m65T	1
41	ZX-A41	Taper Pin	6x40	1
42	GB893.1	C-Clip	40	2
43	ZX-K06106	Bearing Support		1
44	TS-1504041	Hex Socket Cap Screw	M6x16	3
46	GB893.1	C-Clip	42	2
47	ZX-K06712	Shaft		1
48	ZX-K06716	Hand Wheel Shaft	2mx15T	1
49	ZX-H10	Half Circle Key	4x16	1
51	ZX-K06109	End Cover		1
52	TS-1514031	Hex Socket Cap Screw	M6x18	3
53	TL06105	Dial Support		1
54	GB819	Cross Head Screw	M5x14	3
55	TL06732(m)	Dial		1
56	ZX-K06107	Hand Wheel		1
57	ZX-06710	Shaft Driven Lever		1
58	ZX-K06713	Shaft Cover		1
59	GB819	Cross Head Screw	M5x20	1
60	ZX-K06714	Screw		1
62	TL06112	End Cover		1
63	TS-1514011	Hex Socket Cap Screw	M6x12	6
64	TL06733	T Shaped Flat Key		1
65	TL06115	Flange Sleeve		1
66	TS-1514011	Hex Socket Cap Screw	M6x12	3
67	ZX-A67	Flat End Set Screw	M6x30	1
68	TS-1540041	Hex Nut	M6	1
76	TL06109	Flange		1
78	TL06303	Sign Plate		1
79	TL06714	Adjusting Screw		1
80	ZX-A80	Oil Seal	8x1.9	1
81	BB-7203	Ball Bearing	17x40x12	2
82	ZX-K06708	Shaft		1
83	TL06715	Adjusting Rod		1
84	ZX-H10	Half Circle Key	4x16	3
85	TL06712	Spring Cover		1
86	ZX-A86	Spring	YI-4x32x40	1
87	TL06718	Gear	2m28T	1
88	TL06113	Helical Gear	2.5m40T	1
89	BB7006/P6	Ball Bearing	30x55x13	1
90	TS-1523031	Set Screw	M6x10	1
91	ZX-A25	Thread Tail Taper Pin	M6x25	1
92	TL06110	Fork		1
93	ZX-K06707	Control Rod		1
94	ZX-06116E	Lever Support		1
95	ZX-A95E	Cross Head Screw	M6x30	1
96	ZX-H5	Steel ball	8	1
97	ZX-A97	Spring	YI-1x7x25	1
98	ZX-A98	Flat Head Set Screw	M10x16	1
99	ZX-06737E	Bracket		1
100	ZX-06741E	Plug		1
101	ZX-06739E	Gear shaft		1
102	ZX-A102E	Hex head screw	M4x8	1

Apron Assembly II

No.	Part No.	Description	Size	Qty.
103	ZX-A103E	Pin	4x8	1
105	ZX-K06105	Dial Support		1
107	ZX-A107	Pin	6n6x8	1
108	ZX-K06701	Gear		1
109	ZX-K06103	Bearing Seat		1
110	GB70	Hex Socket Cap Screw	M6x20	12
111	ZX-K06718	Control Shaft		1
112	TL06725	Pin		1
113	ZX-K06717	Control Block		1
114	ZX-A114	Oil Seal	20x2.4	1
115	ZX-A115	Oil Seal	50x3.1	1
116	ZX-K06111	Lever Flange		1
117	TS-1514011	Hex Socket Cap Screw	M6x16	3
118	ZX-K06110	Lever Support		1
119	TL06307	Sign Plate		1
120	ZX-K06722	Lever		1
121	ZX-B27	Taper Pin	6x60	1
164	ZX-A164E	Hex head screw	M6x35	3
165	ZX-06738E	Rack		1
167	ZX-06740E	Handle		1
168	ZX-06736E	Washer		1
169	ZX-A169E	Hex head screw	M5x10	1
170	ZX-06303E	Label		1
171	ZX-A171E	Screw	M3x5	4
172	YSS56BJ	Motor	300W,1500r/min	1
173	GB1096	Key	B4x8	1
174	ZX-K06701	Gear		1
175	ZX-K06102	Bearing Seat		1
176	GB894.1	C-Clip	17	1
177	GB308	Steel ball	8	1
178	ZX-K06108	Dial Support		1
179	GB819	Cross head screw	M6x14	3
180	GB73	Flat end set screw	M4x6	3
181	ZX-K06301	Sleeve		1
182	ZX-K06702	Gear		1
183	ZX-K06703	Gear		1
187	G51-2A	Oil Seal	25x2.4	1
188	ZX-K06104	Bearing Seat		1
189	ZX-K06704	Gear		1
190	ZX-K06705	Gear		1
191	TL06301	Sleeve		1
192	GB73	Flat End Set Screw		1
193	ZX-K06711	Gear		1
194	GB72	Set screw	M8x10	1
196	ZX-A196E	Pin	4x16	1
197	ZX-197E	Head screw	M4x5	1
198	ZX-K18711	Bracket		1
199	ZX-199E	Cross head screw	M4x8	2
200	GB70	Hex Socket Cap Screw	M8x25	3

Apron Assembly III

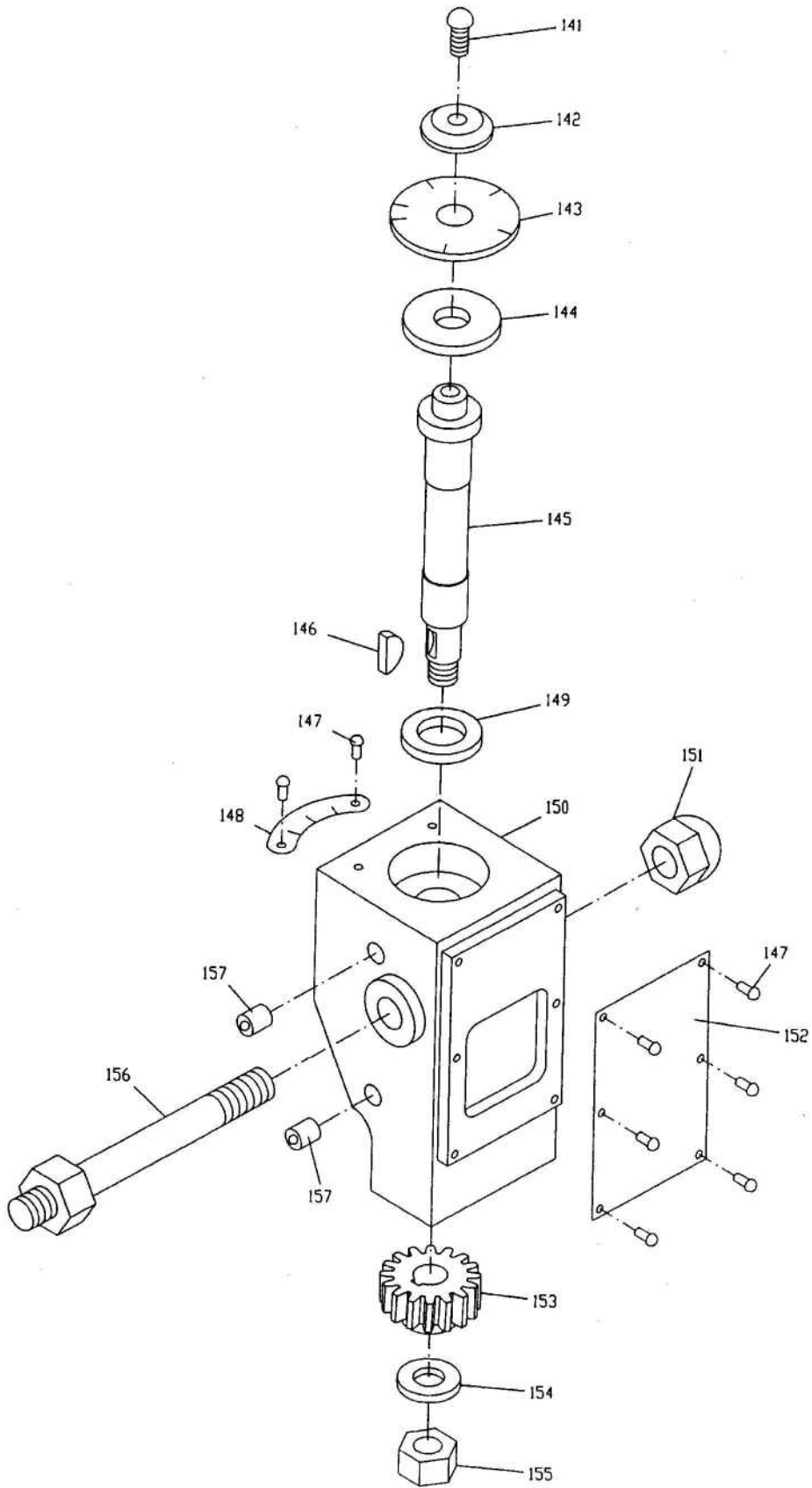

Apron Assembly III

No.	Part No.	Description	Size	Qty.
141	ZX-A141	Half Round Head Screw	M6x18	1
142	ZX-11704	Washer		1
143	ZX-11301	Dial		1
144	ZX-11105	Adjusting Washer		1
145	ZX-11701	Shaft		1
146	ZX-H10	Half Circle Key	4x16	1
147	ZX-A147	Half Round Head Screw	M3x6	8
148	ZX-11303	Positioning Sign Plate		1
149	ZX-11703	Adjusting Washer		1
150	ZX-11101	Casting		1
151	ZX-A151	Acorn Nut	M12	1
152	ZX-11304	Thread Chasing Label		1
153	ZX-11102	Helical Gear	2m15T	1
154	TS-1550071	Flat Washer	M10	1
155	TS-1540072	Hex Nut	M10	1
156	ZX-11702	Bolt		1
157	ZX-A157	Oil Cup	8	2

Carriage Assembly

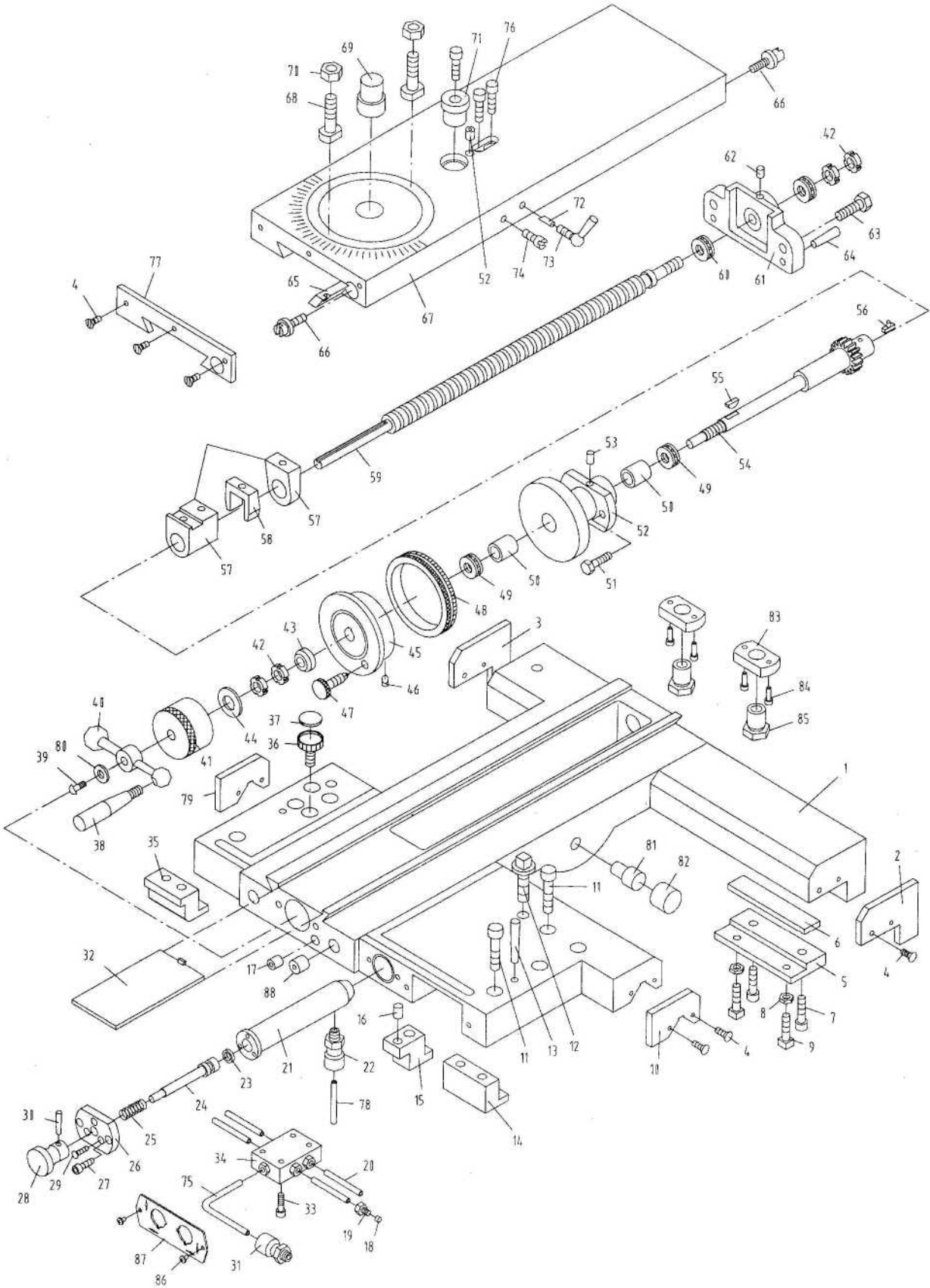

Carriage Assembly

No.	Part No.	Description	Size	Qty.
1	ZX-K04101	Saddle Casting		1
2	ZX-04505	Wipe Plate		1
3	ZX-04504	Wipe Plate		1
4	ZX-H211	Countersunk Head Screw	M5x16	11
5	ZX-04724	Clamping Block		2
6	ZX-04113	Lining Plate		2
7	TS-1516031	Hex Socket Cap Screw	M10x30	4
8	TS-1540061	Hex Nut	M8	4
9	ZX-CA09	Square Set Screw	M8x20	4
10	ZX-04506	Wipe Plate		1
11	TS-1505071	Hex Socket Cap Screw	M10x45	8
12	ZX-CA12	Square Cap Bolt	M12x60	1
13	ZX-CA13	Taper Pin	8x60	2
14	ZX-04729	Clamping Block		1
15	ZX-04730	Locking Plate		1
16	ZX-CA16	Pin	4n6x12	1
17	ZX-K04772	Blocking Piece		1
18	ZX-CA18	Fitting Joint Seal	A4	8
19	ZX-CA19	Hollowed Bolt	A4	8
20	ZX-CA20	Copper Tube		4
21	ZX-04782	Manual Oil Pump Casting		1
22	ZX-04781A	In Valve		1
23	ZX-CA23	Oil Ring	15x2.4	1
24	ZX-04784	Piston		1
25	ZX-CA25	Spring	1.2x14x65	1
26	ZX-04785	Oil Pump Cover		1
27	TS-1513031	Hex Socket Cap Screw	M5x16	2
28	ZX-04783	Lever		1
29	ZX-CA29	Countersunk Head Screw	M4x16	3
30	ZX-A130	Taper Pin	4x20	1
31	ZX-04781B	Out Valve		1
32	ZX-04716	Chip Guard		1
33	ZX-CA33	Slotted Cheese Head Screw	M5x20	4
34	ZX-04780	Oil Distributor		1
35	ZX-K04740	Clamping Block		1
36	ZX-04750	Oil Cap		1
37	ZX-04301	Oil Indicator Cap		1
38	ZX-04721	Lever		1
39	ZX-CA39	Cross Head Screw	M5x16	1
40	ZX-04720	Handle		1
41	ZX-04769	Sleeve		1
42	ZX-CA42	Round Nut	M12x1.25	4
43	ZX-04719	Lining		1

Carriage Assembly

No.	Part No.	Description	Size	Qty.
44	ZX-04770	Disc Spring		1
45	ZX-04108	Flat Pan		1
46	ZX-04790	Pushing Rod		1
47	ZX-04789	Screw		1
48	ZX-04717	Dial		1
49	BB-51102	Thrust Bearing	15x28x9	2
50	ZX-04111	Sleeve		2
51	TS-1490041	Hex Cap Bolt	M8x25	2
52	ZX-04109	Screw Support(for 14"/16"/18" models)		1
	GH-2280ZX-04109A	Screw Support(for 22" models)		1
53	ZX-CA53	Oil Cup	8	2
54	ZX-K04707-1	Gear Sliding Sleeve(for 14716718" models)	2m,16T	1
	GH-2280ZX-04707-1	Gear Sliding Sleeve(for 22" models)	2m16T	1
55	ZX-H10	Half Circle Key	4x16	1
56	ZX-04751	Flat Key		1
57	ZX-04302	Nut Assembly(for 14"/16"/18" models)		1
	GH-2280ZX-04301	Nut Assembly(for 22" models)		1
58	ZX-04748	Wedge		1
59	ZX-K04707-2(m)	Lead Screw(for 14716718" models)		1
	GH-2280ZX-04707-2	Lead Screw(for 22" models)		1
60	BB-51101/P6	Thrust Bearing	12x26x9	2
61	ZX-04116	Bracket		1
62	ZX-CA62	Oil Cup	6	1
63	TS-1491041	Cap Screw	M10x30	2
64	ZX-CA64	Taper Pin	8x30	2
65	ZX-04731	Cross Slide Gib		1
66	ZX-04725C	Screw		2
67	ZX-K04102	Cross Slide(for 14"/16"/18" models)		1
	GH-2280ZX-04102	Cross Slide(for 22" models)		1
68	ZX-04714	Screw (for 18"/22" models, T-Slot)		2
	ZX-04714C	Screw (for 14"/16" models, T-Slot)		2
69	ZX-04732	Pin		1
70	TS-1540081	Hex Nut	M12	2
71	ZX-04709	Sleeve		1
72	ZX-04304	Pressing Pin		1
73	ZX-04746	Screw		1
74	ZX-04786	Set Screw		1
75	ZX-CA75	Long Copper Tube		1
76	ZX-C76	Socket Head Cap Screw	M8x22	3
77	ZX-04502	Wipe Plate		1
78	ZX-CA78	Copper Tube		6
79	ZX-04503	Wipe Plate		1
80	ZX-04771	Lining		1
81	ZX-04788	Stop Pin		1
82	ZX-04507	Stop Pin Cap		1
83	ZX-K04803	Flange		2
84	GB70	Hex Socket Cap Screw	M5x14	4
85	D96-5	Adaptor	M20x1.5	2
86	GB818	Corrss head screw	M4x6	2
87	ZX-K04321	Plate		1
88	ZX-K04802	Blocking Piece		2

Micro Carriage Stop

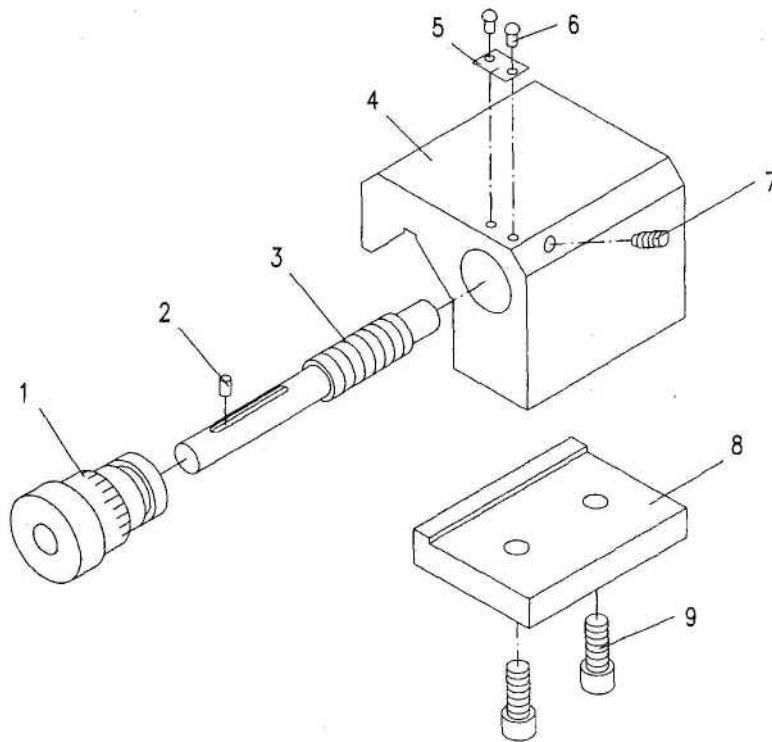

No.	Part No.	Description	Size	Qty.
1	ZX-09709	Dial		1
2	ZX-MS2	Pin	B4x8	1
3	ZX-09708	Axle		1
4	ZX-09105	Stop		1
5	ZX-03302	Sign Plate		1
6	ZX-MS6	Nail	3x8	2
7	ZX-MS7	Hex Socket Set Screw	M6x12	1
8	ZX-09106	Clamping Plate		1
9	ZX-MS9	Hex Socket Cap Screw	M8x20	2

Carriage Stop Assembly

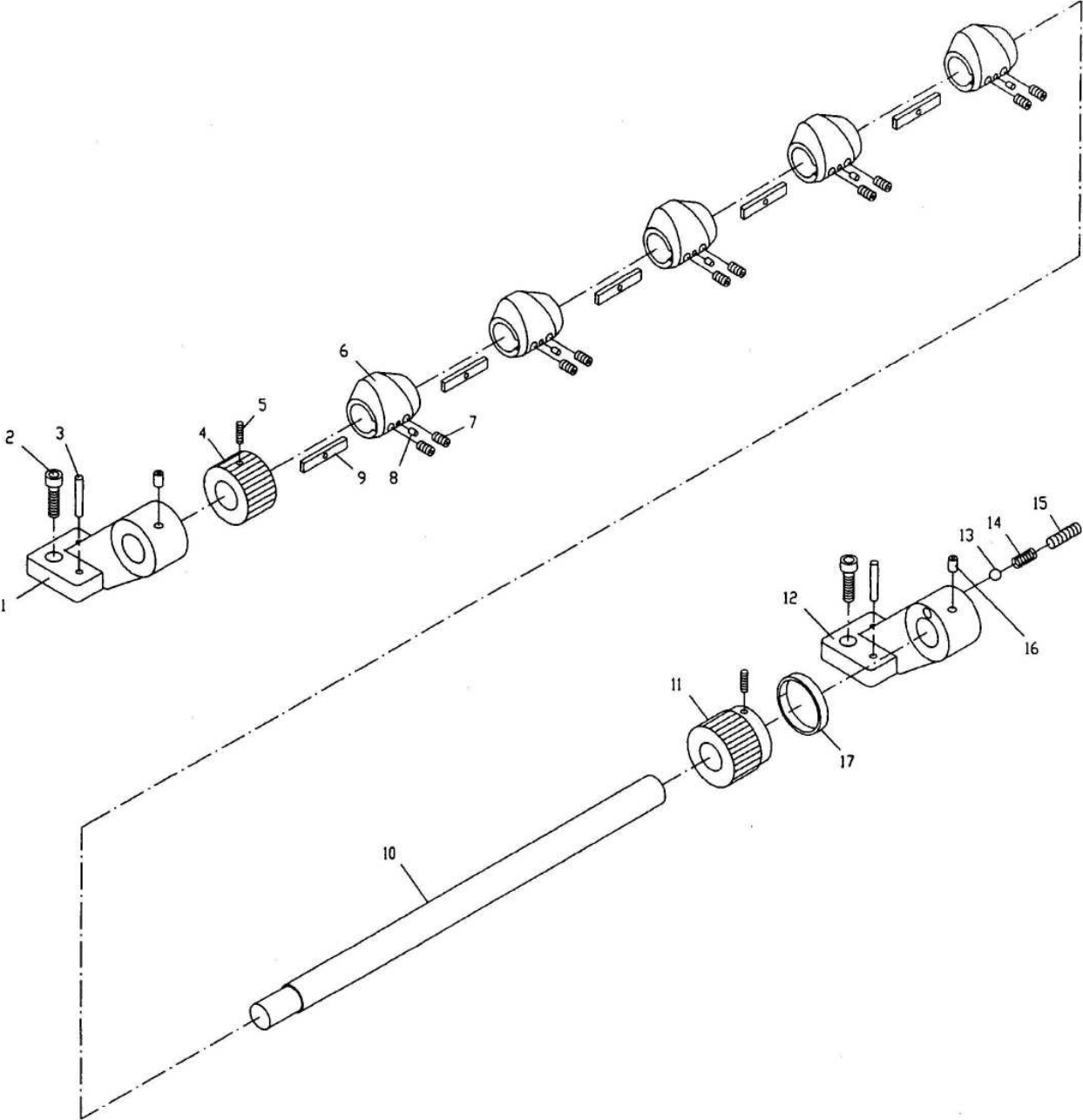

Carriage Stop Assembly

No.	Part No.	Description	Size	Qty.
1	ZX-26101	Left Support		1
2	TS-1504041	Hex Socket Cap Screw	M8x20	4
3	ZX-C34	Taper Pin	6x30	4
4	ZX-26704	Control Ring		1
5	TS-1523031	Set Screw	M6x10	2
6	ZX-26702	Eccentric Travel Setting Ring		5
7	ZX-H66	Flat End Set Screw	M6x10	10
8	ZX-C08	Pin	4n6x10	5
9	ZX-26703	Locking Key		5
10	ZX-26701A	Travel Setting Rod (for 1440/1640/1840ZX)		1
	ZX-26701B	Travel Setting Rod (for 1460/1660/1860ZX)		1
	ZX-26701C	Travel Setting Rod (for 1880/2280ZX)		1
11	ZX-26705	Control Ring		1
12	ZX-26104	Right Support		1
13	ZX-H5	Steel Ball	8	1
14	ZX-CS14	Compression Spring	2x8x25	1
15	ZX-CS15	Flat Head Set Screw	M10x12	1
16	ZX-CS16	Oil Cup	8	2
17	ZX-26301	Dial		1

Four Way Tool Post

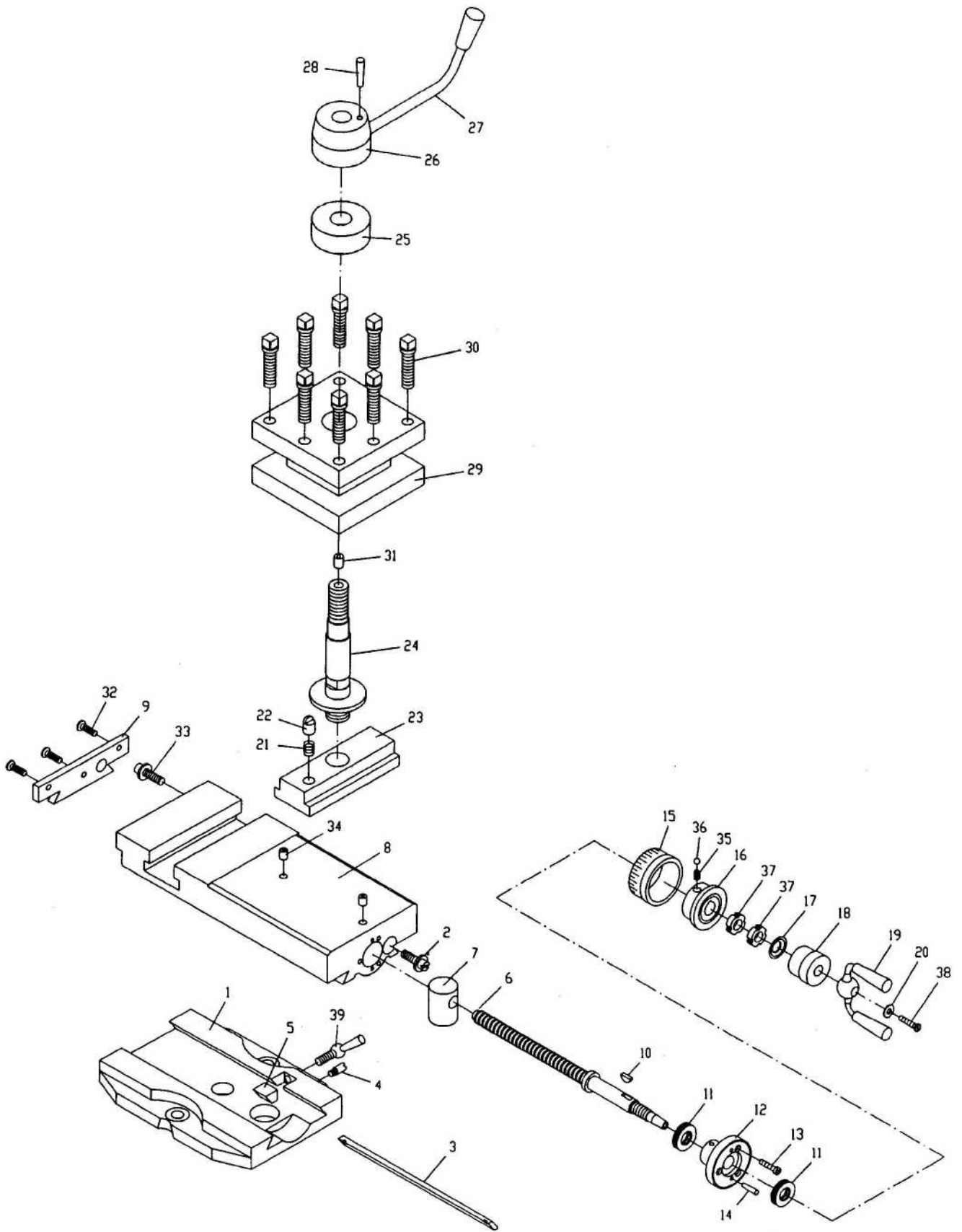

Four Way Tool Post

No.	Part No.	Description	Size	Qty.
1	ZX-04103A	Revolving Plate (for 14" models)		1
	ZX-04103B	Revolving Plate (for 16" models)		1
	ZX-04103C	Revolving Plate (for 18" models)		1
	GH2280ZX-04103	Revolving Plate (for 22" model)		1
2	ZX-04725	Screw		1
3	ZX-04710	Gib		1
4	ZX-04786	Screw		1
5	ZX-04303	Pressing Block		1
6	ZX-04706	Lead Screw		1
7	ZX-04106A	Nut		1
8	ZX-04107A	Top Slide (for 14" models)		1
	ZX-04107B	Top Slide (for 16"/18" models)		1
	GH2280ZX-04107	Top Slide (for 22" model)		1
9	ZX-04501	Wipe Plate		1
10	ZX-F10	Half Circle Key	3x13	1
11	BB-51102	Thrust Bearing	15x28x9	2
12	ZX-04115	Sleeve		1
13	ZX-F13	Slotted Cheese Head Screw	M5x12	3
14	ZX-F14	Taper Pin	3x18	2
15	ZX-04727	Dial		1
16	ZX-04114	Sleeve		1
17	ZX-04768	Disc Spring		1
18	ZX-04767	Sleeve		1
19	ZX-04726	Handle		1
20	ZX-04771	Lining		1
21	ZX-04763	Spring	0.8x6x25	1
22	ZX-04787	Positioning Block		1
23	ZX-04752A	T-Slot Nut		1
24	ZX-04754	Shaft		1
25	ZX-04759	Adjusting Lining Sheet		1
26	ZX-04110	Lever Support		1
27	ZX-04753	Handle		1
28	ZX-Q66	Taper Pin	5x35	1
29	ZX-04713A	Tool Post (for 14" models)		1
	ZX-04713B	Tool Post (for 16"/18"/22" models)		1
30	ZX-F30A	Clamping Screw (for 16"/18"/22" models)	M12x45	8
	ZX-F30B	Clamping Screw (for 14" models)	M12x50	8
31	ZX-F31	Oil Cup	8	1
32	ZX-H211	Countersunk Head Screw	M5x16	3
33	ZX-04725C	Screw		1
34	ZX-F34	Oil Cup	8	2
35	ZX-F35	Spring	0.7x5x9	1
36	ZX-F36	Steel Ball	6	1
37	ZX-F37	Round Nut	M12x1.25	2
38	ZX-CA39	Cross Head Screw	M5x16	1
39	ZX-04746K	Screw Wrench		1
	ZX-TA14	Toolholder Assembly 14" (includes #29 & 30)		
	ZX-TA16/18/22	Toolholder Assembly 16"/18"/22" (includes # 29 & 30)		
	ZX-CPA14	Compound Assembly 14" (includes # 1-20,32-39)		
	ZX-CPA16	Compound Assembly 16" (includes #1-20,32-39)		
	ZX-CPA18	Compound Assembly 18" (includes # 1-20,32-39)		
	ZX-CPA22	Compound Assembly 22" (includes # 1-20,32-39)		

Tailstock Assembly I

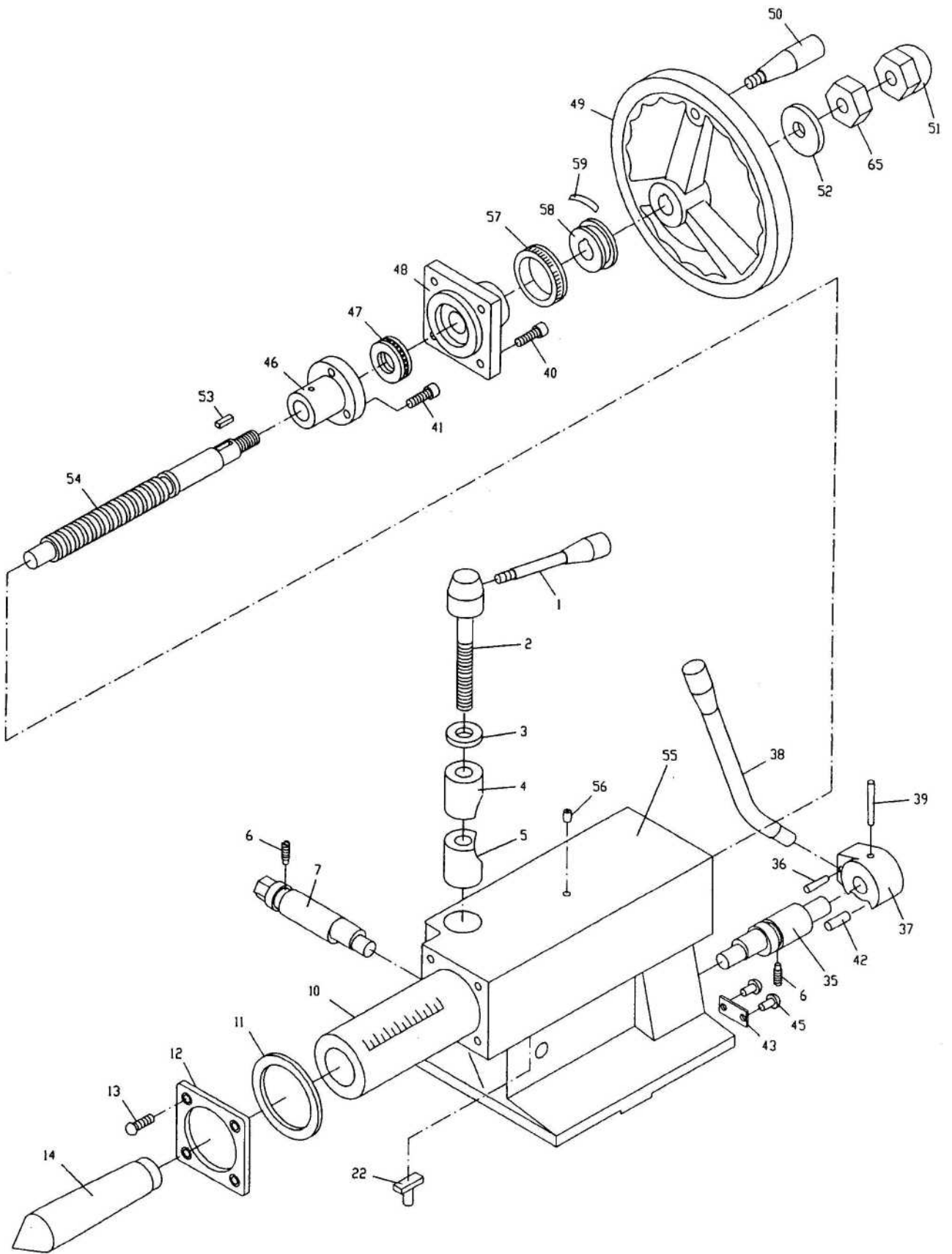

Tailstock Assembly I

No.	Part No.	Description	Size	Qty.
1	ZX-03711	Handle		1
2	ZX-03717	Lever Support		1
3	ZX-03718	Washer		1
4	ZX-03719	Clamping Block		1
5	ZX-03720	Clamping Block		1
6	ZX-T06	Cylindrical End Set Screw	M8x14	2
7	ZX-03712	Eccentric Shaft		1
10	ZX-03701A	Center Sleeve (for 18"/22" models)		1
	ZX-03701B	Center Sleeve (for 14"/16" models)		1
11	ZX-T11	Ring Seal	75x2.65	1
12	ZX-03703	Front Cover	1	
13	ZX-T13	Cross Recessed Countersunk Head Screw	M5x10	4
14	ZX-T14A	Center Morse (for 18"/22" models)	No.5	1
	ZX-T14B	Center Morse (for 14"/16" models)	No.4	1
22	ZX-03702	Positioning Block		1
35	ZX-03714	Eccentric Shaft		1
36	ZX-T36	Taper Pin	6x32	1
37	ZX-03104	Lever Sleeve		1
38	ZX-03709	Lock handle		1
39	ZX-A28	Taper Pin	6x55	1
40	TS-1504041	Hex Socket Cap Screw	M8x20	4
41	TS-1515031	Hex Socket Cap Screw	M8x22	3
42	ZX-T42	Pin	10n6x22	1
43	ZX-03302	Sign Plate		1
45	ZX-T45	Nail	3x8	4
46	ZX-03105	Nut		1
47	BB-51205	Thrust Ball Bearing	25x47x15	1
48	ZX-03104	Back Cover		1
49	ZX-03103	Hand Wheel		1
50	ZX-03707	Lever		1
51	ZX-T51	Acorn Nut	M16	1
52	TS-155010	Flat Washer	M16	1
53	ZX-T53	Key	6x40	1
54	ZX-03710A	Lead Screw (for 18"/22" models)		1
	ZX-03710B	Lead Screw (for 14"/16" models)		1
55	ZX-03101A	Tailstock Casting (for 18" models)		1
	ZX-03101B	Tailstock Casting (for 16" models)		1
	ZX-03101C	Tailstock Casting (for 14" models)		1
	GH2280ZX-03101	Tailstock Casting (for 22" model)		1
56	ZX-T56	Oil Cup	8	1
57	ZX-03708	Dial		1
58	ZX-03706	Sleeve		1
59	ZX-03711C	Spring Leaf		1
65	TS-2310162	Nut	M16	1

Tailstock Assembly II

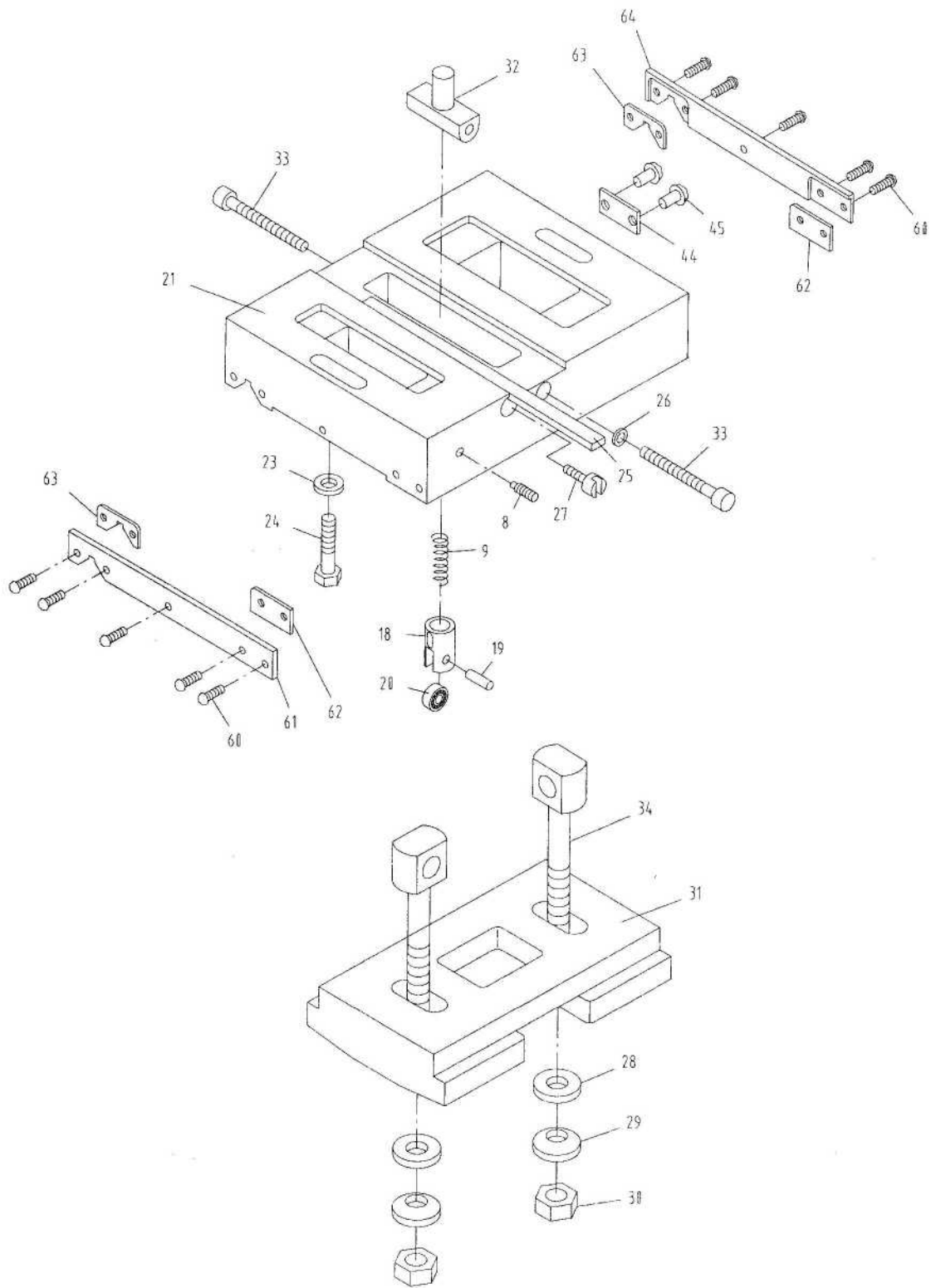

Tailstock Assembly II

No.	Part No.	Description	Size	Qty.
8	ZX-T08	Flat End Set Screw (except in 14" models)	M6x18	4
9	ZX-T09E	Spring		1
18	ZX-03714	Bearing Support (Except in 14" models)		4
19	ZX-03715	Small Axle (Except in 14" models)		4
20	ZX-T20	Ball Bearing (Except in 14" models)	7x19x6	4
21	ZX-03102A	Sliding Base (for 18"/22" models)		1
	ZX-03102B	Sliding Base (for 16" models)		1
	ZX-03102C	Sliding Base (for 14" models)		1
23	TS-1550071	Flat Washer	M10	2
24	TS-1491151	Hex Cap Bolt (for 18"/22" models)	M10x90	2
	TS-1491121	Hex Cap Bolt (for 16" models)	M10x70	2
	TS-1491081	Hex Cap Bolt (for 14" models)	M10x50	2
25	ZX-03704	Gib		1
26	ZX-03721C	Spherical Washer		2
27	ZX-03718C	Adjusting Screw		2
28	ZX-T28	Taper Washer	16	2
29	ZX-T29	Spherical Washer	16	2
30	TS-2310162	Hex Nut	M16	2
31	ZX-03106	Clamping Bracket		1
32	ZX-03105C	Nut		1
33	ZX-T33	Hex Socket Cap Screw	M8x85	2
34	ZX-03705A	Pulling Rod (for 18"/22" models)		2
	ZX-03705B	Pulling Rod (for 16" models)		2
	ZX-03705C	Pulling Rod (for 14" models)		2
44	ZX-03303	Sign Plate		1
45	ZX-T45	Nail	3x8	4
60	ZX-T60	Half Round Head Screw	M5x12	10
61	ZX-03721	Plate		1
62	ZX-03502	Wipe Plate		2
63	ZX-03503	Wipe Plate		2
64	ZX-03716	Plate		1
	ZX-TSA14	Tailstock Assembly, 14" (includes # 1-13,15-65)		
	ZX-TSA16	Tailstock Assembly, 16" (includes* 1-13,15-65)		
	ZX-TSA18	Tailstock Assembly, 18" (includes # 1-13,15-65)		
	ZX-TSA22	Tailstock Assembly, 22" (includes #1-13,15-65)		

Steady Rest Assembly

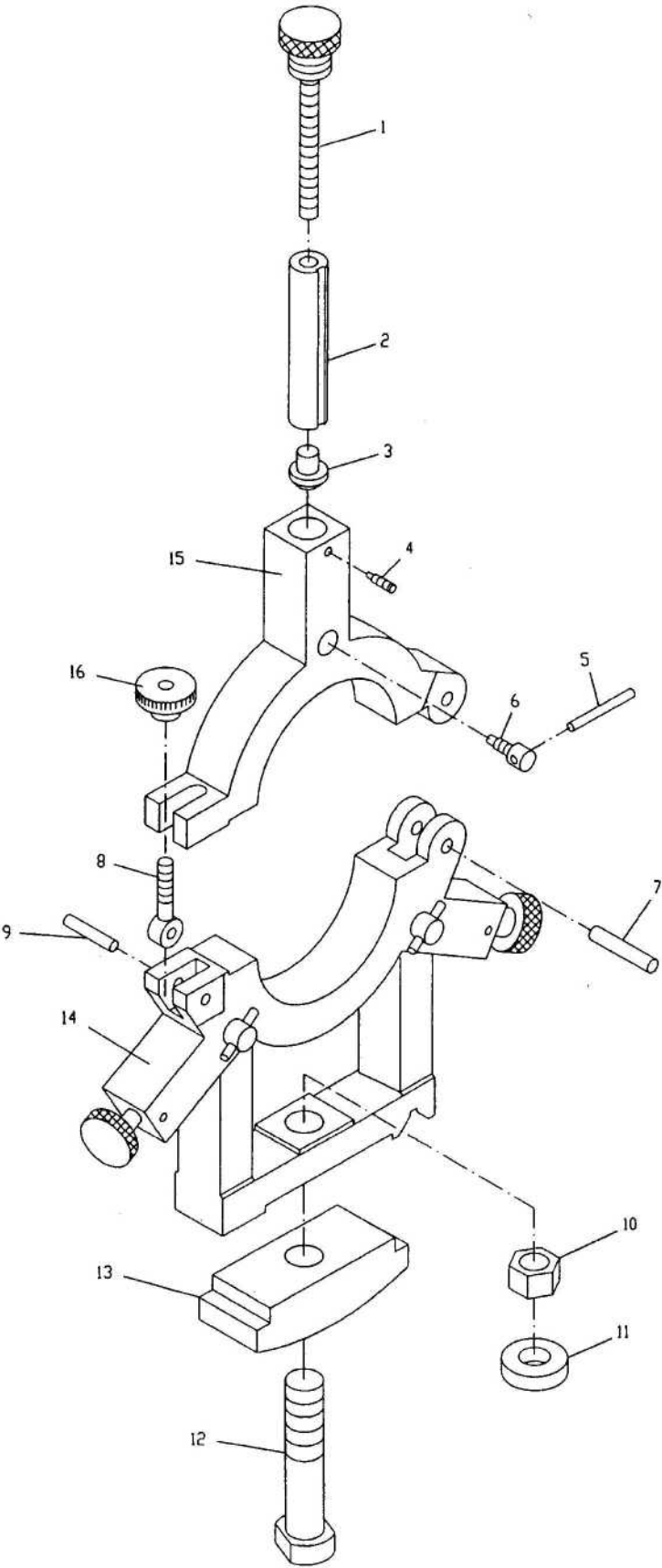

Steady Rest Assembly

No.	Part No.	Description	Size	Qty.
1	ZX-10702A	Screw (for 14" models)		3
	ZX-10702B	Screw (for 16" models)		3
	ZX-10702C	Screw (for 18"/22" models)		3
2	ZX-10704D	Sliding Sleeve	90-180	3
	ZX-10705D	Sliding Sleeve	20-210	3
3	ZX-10301D	Pushing Block		3
4	ZX-SR04	Slotted Set Screw	M6x20	3
5	ZX-10705	Lever		3
6	ZX-10706	Locking Screw		3
7	ZX-C36	Pin	10n6x40	1
8	ZX-10701F	Hinge Screw		1
9	ZX-SR9	Pin	8n6x40	1
10	ZX-SR10	Hex Nut	M20	1
11	ZX-SR11	Flat Washer	20	1
12	ZX-10708	Tightening Screw		1
13	ZX-10103D	Clamping Plate		1
14	ZX-10101A	Lower Part of Steady Rest (for 14" models)		1
	ZX-10101B	Lower Part of Steady Rest (for 16" models)		1
	ZX-10101C	Lower Part of Steady Rest (for 18" models)		1
	GH2280ZX-10101	Lower Part of Steady Rest (for 22" model)		1
15	ZX-10102AS	Upper Part of Steady Rest (for 14" models)		1
	ZX-10102BS	Upper Part of Steady Rest (for 16"/18" models)		1
	ZX-10102F	Upper Part of Steady Rest (for 22" model)		1
16	ZX-SR16	Round Nut	M10	1
	ZX-SRA14	Steady Rest Assembly, 14" (includes # 1-16)		
	ZX-SRA16	Steady Rest Assembly, 16" (includes # 1-16)		
	ZX-SRA18	Steady Rest Assembly, 18" (includes # 1-16)		
	ZX-SRA22	Steady Rest Assembly, 22" (includes #1-16)		

Follow Rest Assembly

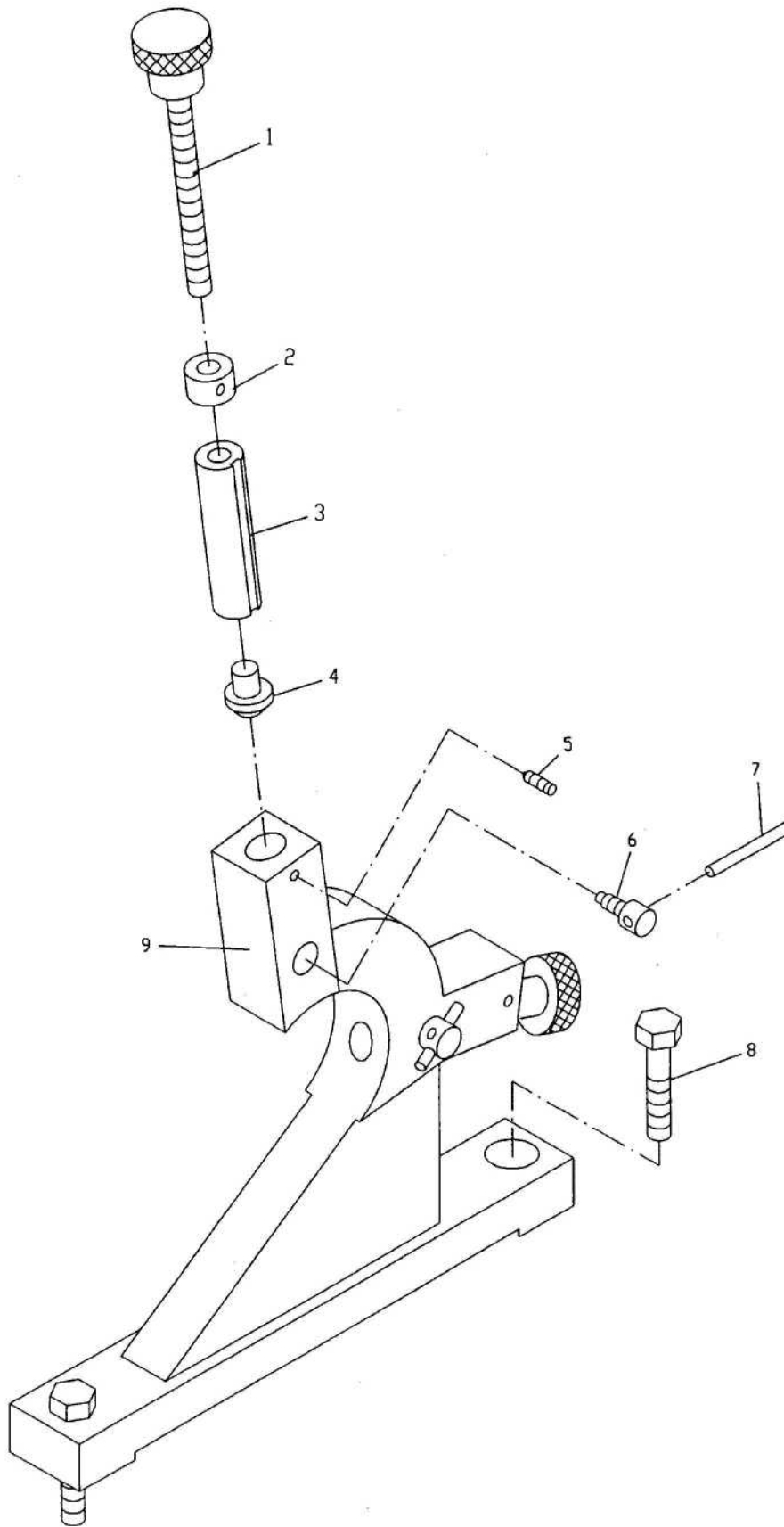

Follow Rest Assembly

No.	Part No.	Description	Size	Qty.
1	ZX-10710	Screw		2
2	ZX-10704	Nut		2
3	ZX-10707	Sliding Sleeve		2
4	ZX-10301	Supporting Piece		2
5	ZX-FR05	Slotted Set Screw	M6x10	2
6	ZX-10705	Locking Screw		2
7	ZX-10706	Handle		2
8	ZX-FR8	Hex Cap Bolt	M12x55	2
9	ZX-10102A	Follow Rest Casting (for 14" models)		1
	ZX-10102B	Follow Rest Casting (for 16" models)		1
	ZX-10102C	Follow Rest Casting (for 18" models)		1
	GH2280ZX-10102	Follow Rest Casting (for 22" model)		1
	ZX-FRA14	Follow Rest Assembly, 14" (includes #1-7,9)		
	ZX-FRA16	Follow Rest Assembly, 16" (includes #1-7,9)		
	ZX-FRA18	Follow Rest Assembly, 18" (includes #1-7,9)		
	ZX-FRA22	Follow Rest Assembly, 22" (includes #1-7,9)		

Coolant & Work Light Assembly

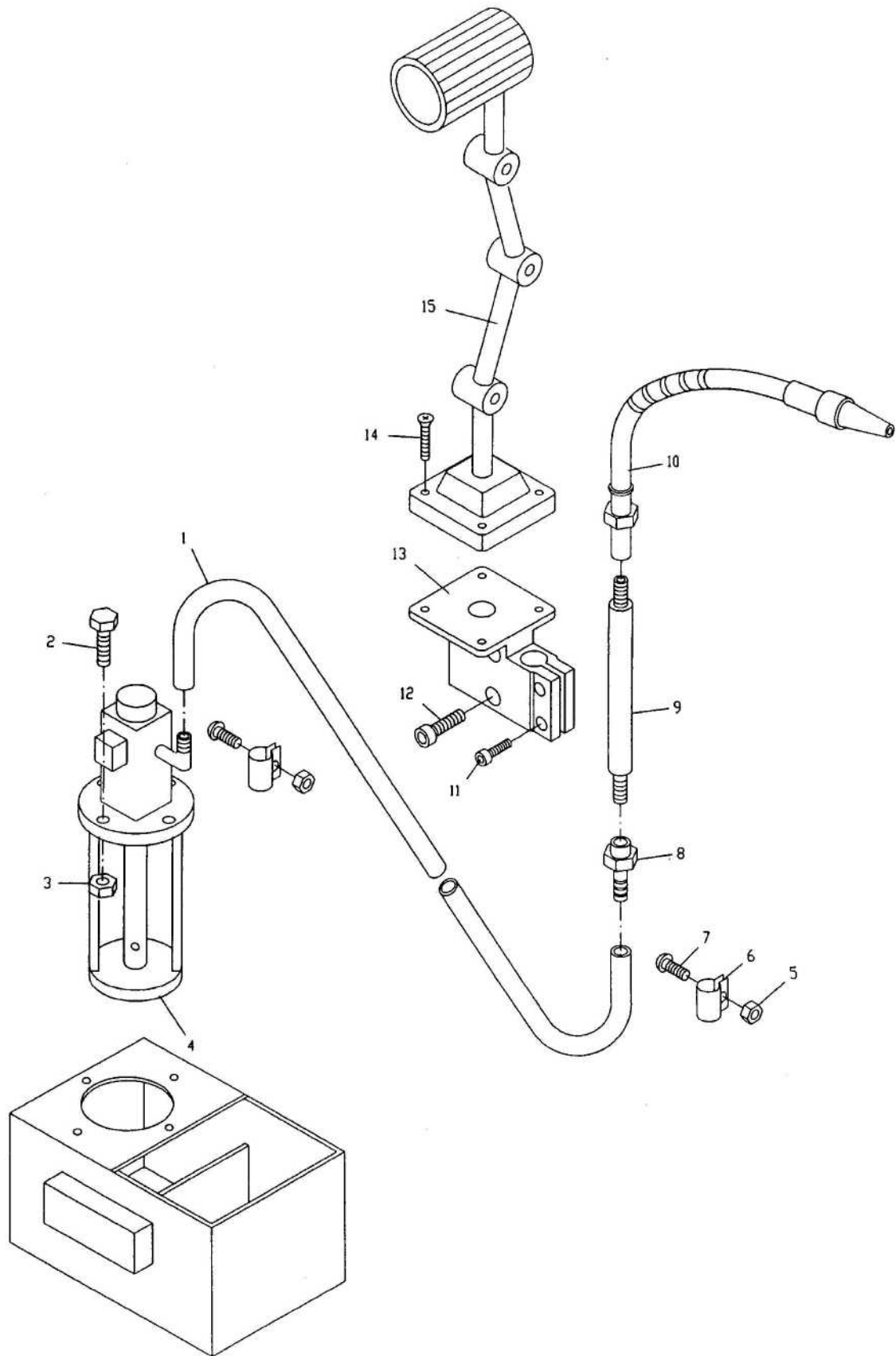

Coolant & Work Light Assembly

No.	Part No.	Description	Size	Qty.
1	RT-001A	Rubber Tube (for 1440/1640/1840ZX)	ID 1/2"x1280mm	1
	RT-001B	Rubber Tube (for 1460/1660/1860ZX)	ID 1/2"x1780mm	1
	RT-001C	Rubber Tube (for 1880/2280ZX)	ID 1/2"x2280mm	1
2	ZX-CW02	Hex Cap Bolt	M5x25	4
3	ZX-CW03	Hex Nut	5	4
4	ZX-CW04	Coolant Pump		1
5	ZX-CW05	Hex Nut	M6	2
6	ZX-01727	Clip For Rubber Tube		2
7	ZX-CW07	Half Round Head Screw	M6x16	2
8	ZX-01728	Fitting		1
9	ZX-01729	Flow Pipe		1
10	ZX-CW10	Coolant Device		1
	ZX-CW10-1	Coolant Tap	G 3/8"	1
11	TS-1514021	Hex Socket Cap Screw	M6x16	2
12	TS-1515051	Hex Socket Cap Screw	M8x40	2
13	ZX-CW13	Lamp Support		1
14	ZX-S04	Cross Head Screw	M6x14	4
15	ZX-CW15	Lamp Frame		1
	ZX-CW16	Bulb	50W,AC24V	1
	ZX-LA	Light Assembly (includes # 13-15)		

Micro Carriage Stop

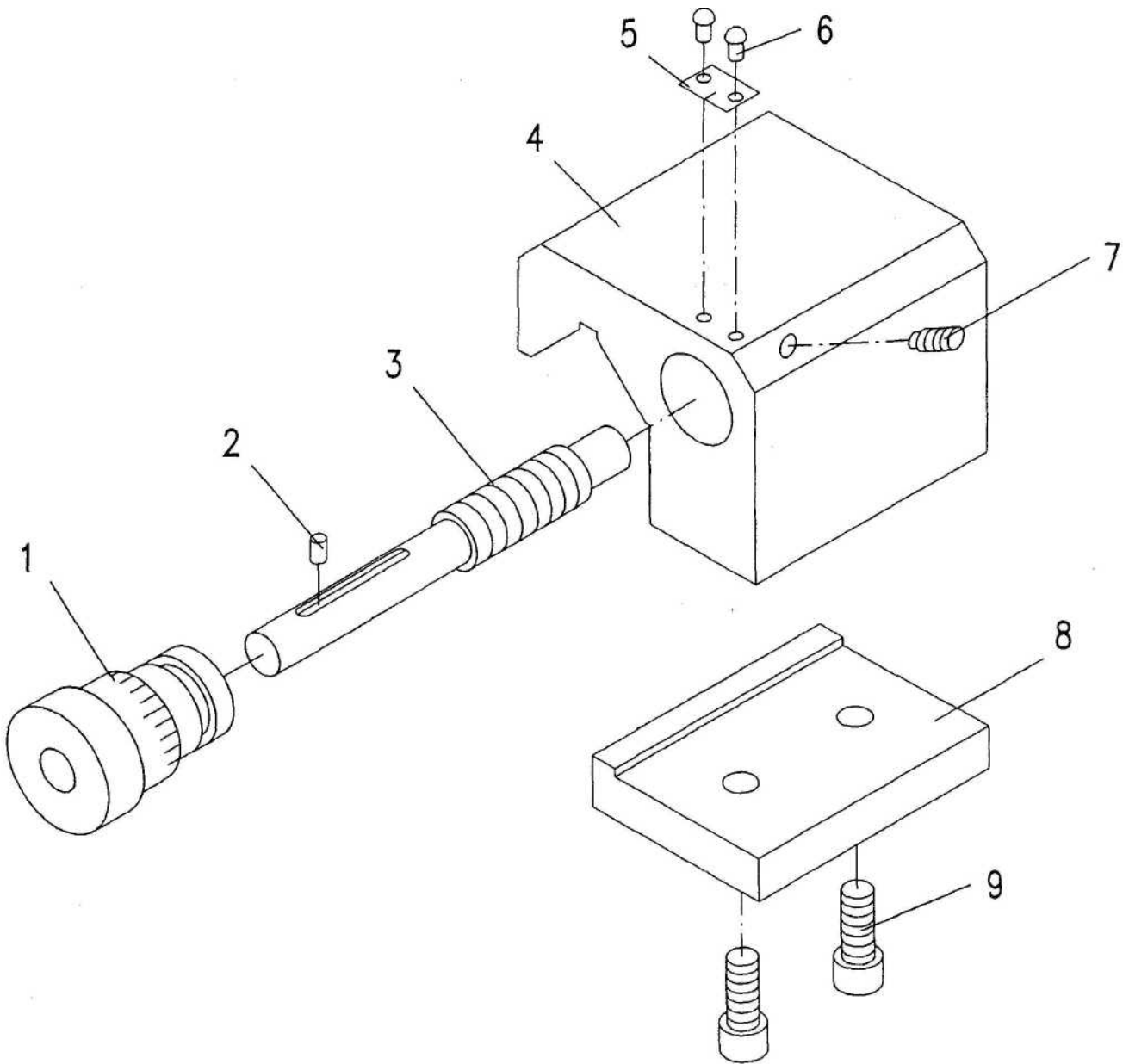

No.	Part No.	Description	Size	Qty.
1	ZX-09709	Dial		1
2	ZX-MS2	Pin	B4x8	1
3	ZX-09708	Axle		1
4	ZX-09105	Stop		1
5	ZX-03302	Sign Plate		1
6	ZX-MS6	Nail	3x8	2
7	ZX-MS7	Hex Socket Set Screw	M6x12	1
8	ZX-09106	Clamping Plate		1
9	ZX-MS9	Hex Socket Cap Screw	M8x20	2

Other Parts

No.	Part No.	Description	Size	Qty.
1A	ZX-OP-1A	3-Jaw Chuck (mounted on lathe)	10", D1-8	1
1B	ZX-OP-1B	Chuck Wrench		1
2A	ZX-OP-2A	4-Jaw Chuck	12", D1-8	1
2B	ZX-OP-2B	Chuck Wrench		1
3	ZX-OP-03	12" Face Plate (for 14716" models)		1
	ZX-OP-03N	16" Face Plate (for 18"/22" models)		1
4	ZX-OP-04	Tool Tightening Wrench		1
5	ZX-OP-05	Cam Tightening Wrench		1
6	ZX-OP-06	Center		1
7	ZX-OP-07	MT-4 Live Center (for 14716" models)		1
	ZX-OP-07N	MT-5 Live Center (for 18"/22" models)		1
8	ZX-OP-08	Morse Reduction Sleeve		1
9	ZX-OP-09	Oil Gun		1
10	ZX-OP-10	Touchup Paint Can		1
11	ZX-OP-11	Gap Bridge Pin Driver		1
12	ZX-OP-12	Hex Wrench	2,5,4,5,6,8,10	1
13	ZX-OP-13	Double End		1
14	ZX-OP-14	Flat Blade Screw Driver		1
15	ZX-OP-15	Cross Point Screw Driver		1
16	ZX-OP-16	Adjustable Wrench		1
17	ZX-OP-17	Round Nut Wrench		1
	ZX-14/16TBCP	Tool Box Complete (not shown)	ZX-14"/16"	
	ZX-18TBCP	Tool Box Complete (not shown)	ZX-18"/22"	

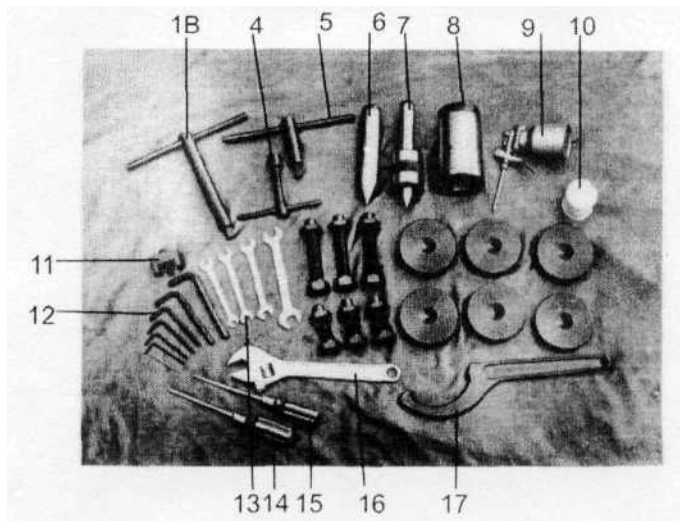
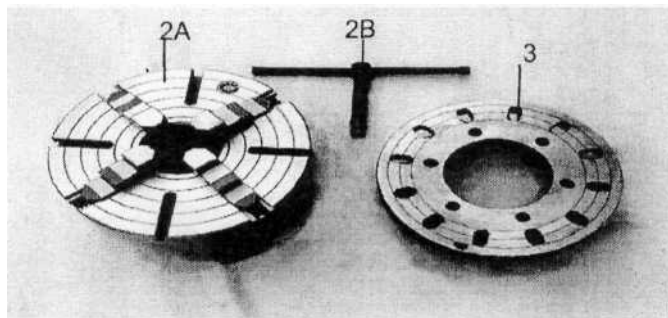

Electrical Cabinet

No.	Part No.	Description	Size	Qty.
1	ZX-SB1E	Jog Button	LAY3-11	1
2	ZX-SA2E	Coolant Control Button	LAY3-11X/2	1
3	ZX-SB2E	Emergency Stop	LAY3-01ZS/1	1
4	ZX-HLE	Power Indicator Light	AD11-30/201	1
5	ZX-SB3E	Emergency Stop	LAY3-01ZS/1	1
6	ZX-SA3E	Turning Switch	ZB2-BZ101C1	1
7	ZX-QF	MasterSwitch (40A)	DZ15-40	1
8	zx-fu1	Fuse(3A)	jrt1-i6a"	1
9	ZX-FU2	Fuse(2A)	JRT1-16A	1
10	ZJ-FU3	Fuse(3A)	JRT1-16A	1
11	ZX-FU5	Fuse(3A)	JRT1-16A	1
	ZX-FBE	Fuse Block		1
12	ZX-KTE	Time Relay	ST3P	1
13	ZX-KAE	Relay	3TB80	1
14	ZX-KM5-KM7E	A.C. Contactor	3TB40	3
15	ZX-KM1-KM4E	A.C. Contactor	3TB43	4
16	ZX-TCE	Control Transformer	JBK3-100TH	1
17	ZX-XBE	Copper Plate (for grounding)		1
18	ZX-XT1E	Wiring Board		1
19	SQ1.SQ6E	Stroke Switch	LXW5-11N1	2
20	SQ2SQ3E	Stroke Switch	LXW5-11D1	2
21	SQ4SQ7E	Stroke Switch	LXW5-11Q1	2
22	SQ5E	Stroke Switch	LXW3	1
23	ZX-QE	Temperature Relay	JW6	1

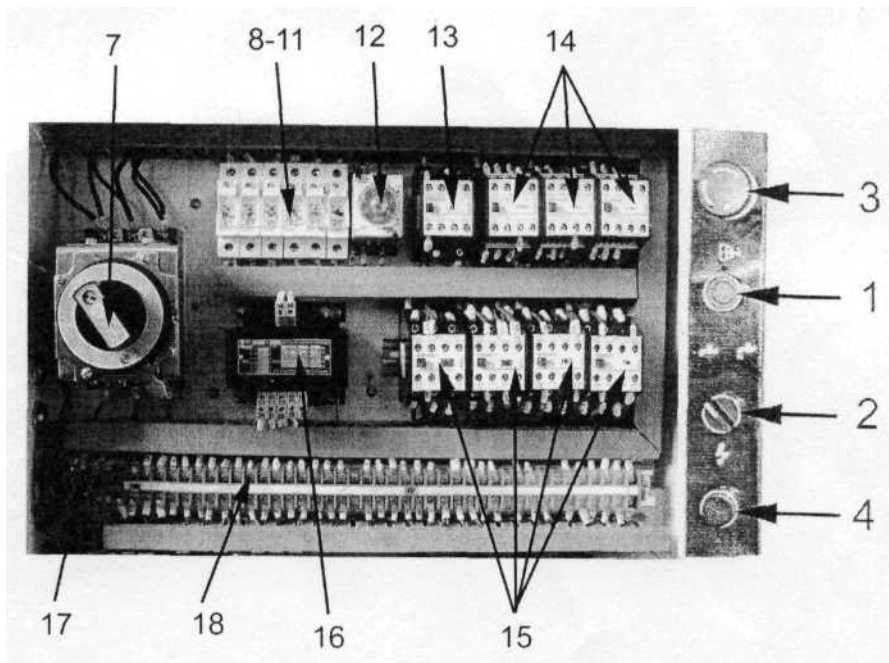

Wiring Diagram

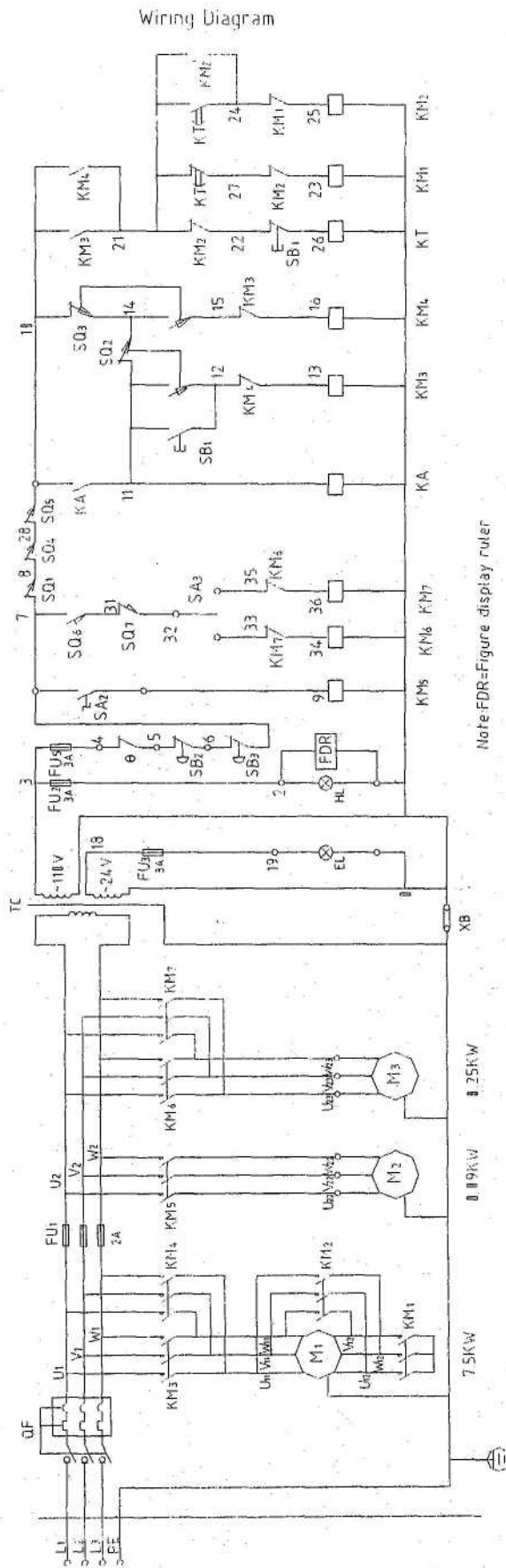

Parts List for Lead Screw Protection Device

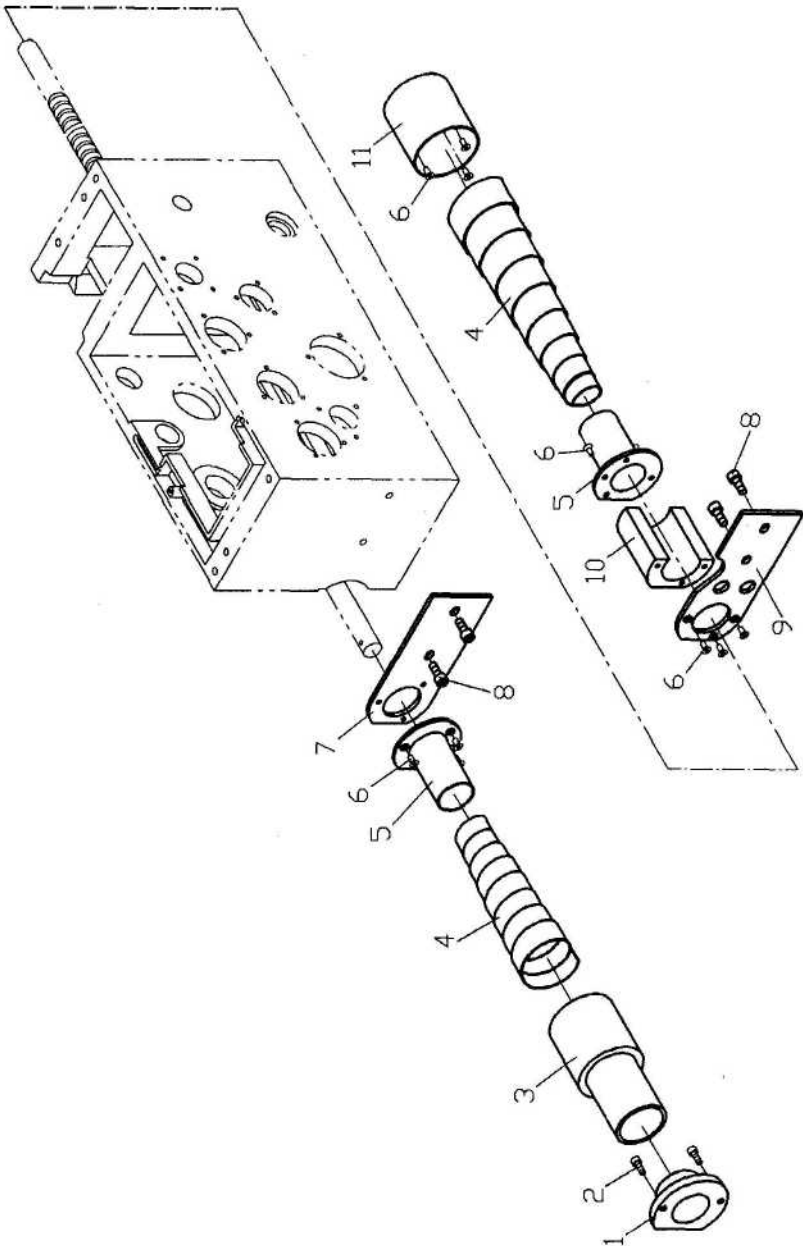

No.	Part No.	Description	Size	Qty.
1	1440R-07101	Cover		1
2	GB819	Cross Recessed Head Screw	M5x12	2
3	1440R-07701A	Left Flange		1
4	LGB45-1000-100	Telescoping Sheet Cover(1000 Size)		2
	LGB45-1500-120	Telescoping Sheet Cover(1500 Size)		2
5	1440R-07702A	Flange		1
6	GB819	Cross Recessed Head Screw	M5x12	10
7	1440R-07703A	Left Bracket		1
8	GB70	Hex Socket Cap Screw	M8x20	4
9	1440R-07704A	Right Bracket		1
10	1440R-07706A	Sleeve		1
11	1440R-07705A	Right Flange		1

Safety Guard Cover

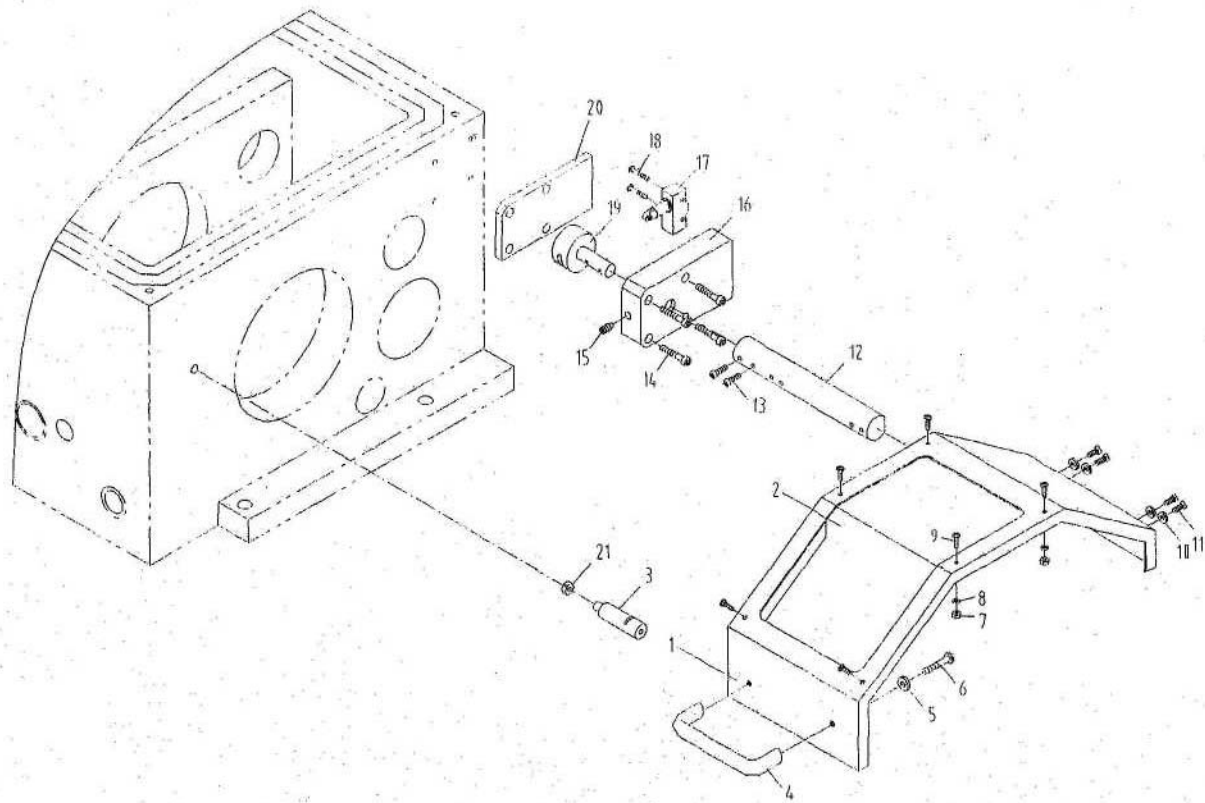

No.	Part No.	Description	Size	Qty.
1	ZX-19701E	Protection guard		1
2	ZX-19501E	Protection guard visual glass		1
3	ZX-19704E	Fixing rod		1
4	ZX-S04E	Handle	Z96-6	1
5	ZX-S05E	Plain washers	6	2
6	ZX-S06E	Cross recessed pan head screws	M6x12	2
7	ZX-S07E	Hexagon thin nuts	M4	6
8	ZX-S08E	Plain washers	4	6
9	ZX-S09E	Cross recessed pan head screws	M4x12	6
10	ZX-S10E	Plain washers	5	4
11	ZX-S11E	Hexagon socket cap head screws	M5x16	4
12	ZX-19703E	Rest bar		1
13	ZX-S13E	Slotted set screws	M8x10	2
14	ZX-S14E	Hexagon socket cap head screws	M6x35	4
15	ZX-S15E	Hexagon socket set screws	M8x16	1
16	GH1440A-19101E	Switch box		1
17	ZX-S17E	Stroke switch	LXW5-11Q1	1
18	ZX-S18E	Slotted pan head screws	M4x25	2
19	ZX-19702E	Shaft		1
20	ZX-19502E	Washer		1
21		Nut	M8	1

Parts List for Toolpost Protection device

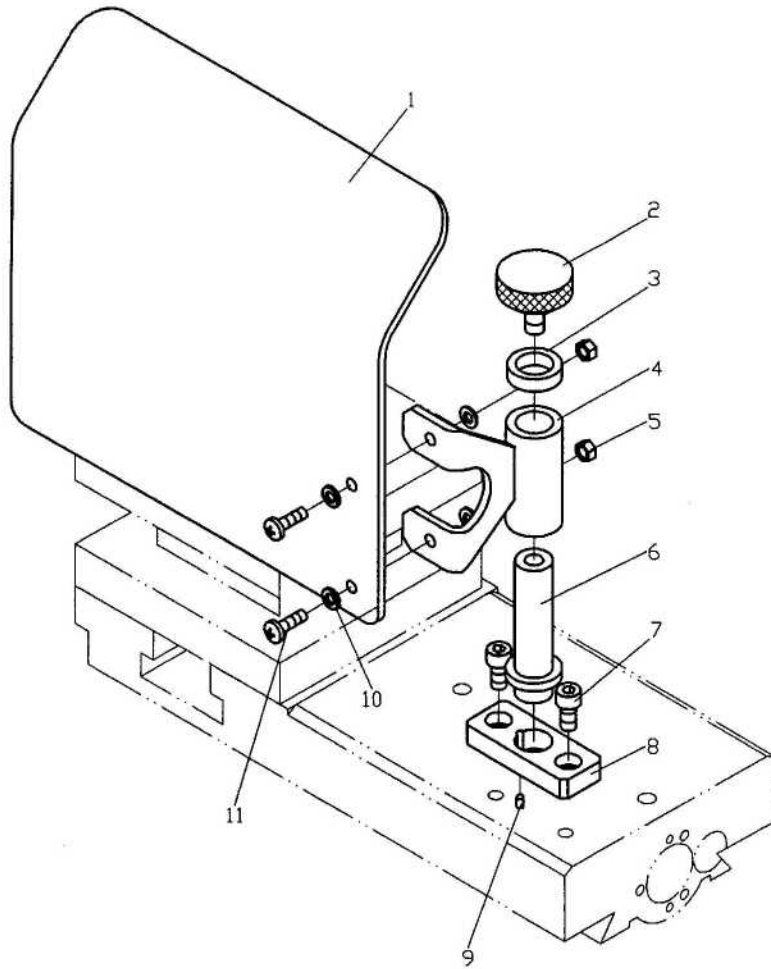

No.	Part No.	Description	Size	Qty.
1	GH-1640ZX-20501	Shield		1
2	GH-1640ZX-20701	Clamping Screw		1
3	GH-1640ZX-20703	Washer		1
4	GH-1640ZX-20704	Sleeve		1
5	GB6170	Nut	M6	2
6	GH-1640ZX-20705-1	Bracket		1
7	GB70	Hex Socket Cap Screw	M8x16	2
8	GH-1640ZX-20705-2	Bracket		1
9	GB71	Slotted Set Screw	M4x8	1
10	GB97	Washer	6	4
11	GB818	Cross Recessed Pan Head Screw	M6x20	2