

JET

JWBS-20X WOODWORKING BANDSAW

708752XM...230/50/1

708752XT ...400/50/3

**PARTS LIST
ERSATZTEILLISTE
LISTE DE PIECES**

WMH Tool Group AG

Bahnstrasse 24, CH – 8603 Schwerzenbach

www.wmhtoolgroup.ch; info@wmhtoolgroup.ch

Tel +41 (0) 44 806 47 48

Fax +41 (0) 44 806 47 58



P-708752XM / 708752XT 09/06

Upper Wheel Assembly

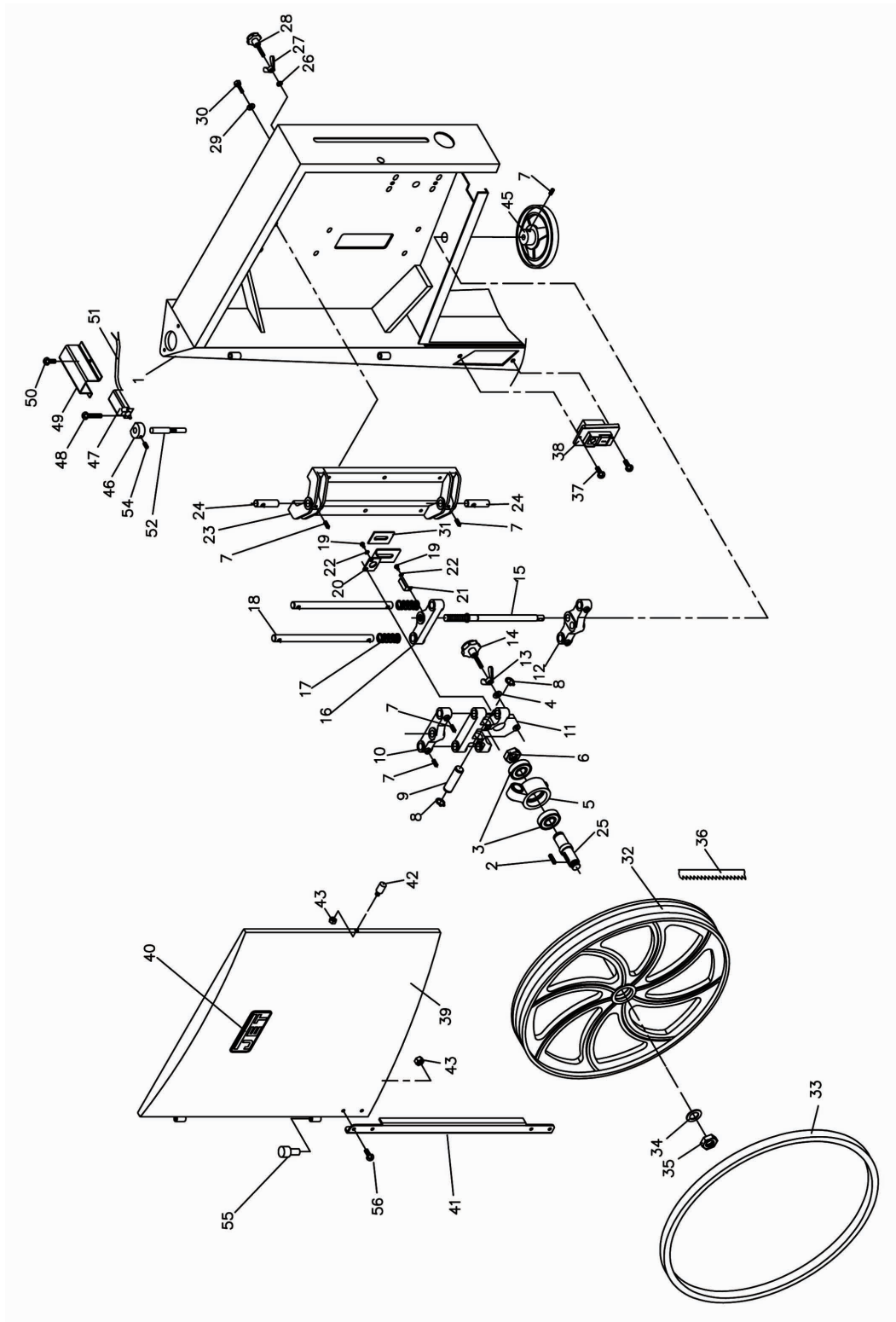

Parts List for the JWBS-20 Bandsaw

Upper Wheel Assembly

Index No.	Part No.	Description	Size	Qty.
1	JWBS20X-501E	Saw Body		1
2	JWBS20-49	Key	7 x 7 x 25	1
3	BB-6205LLU	Ball Bearing	6205	2
4	TS-0720091	Lock Washer	3/8	1
5	JWBS20-44	Upper Wheel Bracket		1
6	JWBS20-506	Lock Nut	3/4-16 UNF R.H	1
7	TS-0270051	Socket Set Screw	5/16-18 x 1/2	5
8	JWBS20-40	C-Ring	S-20	2
9	JWBS20-43	Lever Shaft		1
10	JWBS20-42	Upper Adjustment Bracket		1
11	JWBS20-39	Upper Wheel Guide Bracket		1
12	JWBS20-38	Adjustment Bracket		1
13	JWBS20-41A	Wing Nut		1
14	JWBS20-41	Lock Knob		1
15	JWBS20-37	Adjustment Screw		1
16	JWBS20-36	Elevator Bracket		1
17	JWBS20-35	Spring		2
18	JWBS20-34	Guide Bar		2
19	TS-081C042	Screw	#10-24x5/8	3
20	JWBS20-56B	Bracket		1
21	JWBS20-56A	Pointer		1
22	TS-0720051	Lock Washer	#10	3
23	JWBS20-33	Upper Wheel Bracket Base		1
24	JWBS20-32	Bracket Shaft		2
25	JWBS20-525	Upper Wheel Shaft		1
26	TS-0720081	Lock Washer	5/16	2
27	TS-0590061	Wing Nut	5/16	2
28	JWBS20-54	Lock Knob		2
29	TS-0680041	Flat Washer	3/8	6
30	TS-0060081	Hex Cap Bolt	3/8-16x1-3/4	6
31	JWBS20-56E	Blade Tension Indicator		1
32	JWBS20-532	Upper Wheel		1
33	JWBS20-21	Tire		1
34	Ts-0680091	Flat Washer	3/4	1
35	JWBS20-22	Hex Nut	3/4-16UNF L.H.	1
36	709482	1/4" x 0.025" x 6 Skip Blade	150"	1
	709483	3/8" x 0.025" x 4 Skip Blade	150"	1
	709484	1/2" x 0.025" x 3 Hook Blade	150"	1
	709485	3/4" x 0.032" x 3 Hook Blade	150"	1
	709486	1" x 0.035" x 2 Hook Blade	150"	1
	709487	1-1/4" x 0.035" x 1.3 H00k Blade	150"	1
37	TS-081C022	Screw	#10-24x3/8	2
38	JWBS18DX-107E	Switch	1Ph	1
	JWBS18DX-107AE	Switch	3Ph	1
39	JWBS20X-539E	Upper Front Door		1
40	JWBS18-140	JET Plaque		1
41	JWBS20X-540E	Door Plate		1
42	JWBS20-542	Door Stud		1

Index No.	Part No.	Description	Size	Qty.
43	TS-0561011	Hex Nut	1/4-20	5
45	JWBS20-50	Hand Wheel		1
46	JWBS18-146E	Set Block		1
47	JWBS18DX-147E	Limited Switch		1
48	JWBS18-148E	Screw	M4x30	2
49	JWBS18-149E	Switch Cover		1
50	TS-1480031	Screw	M4x12	2
51	JWBS18DX-151E	Switch Cord (switch to limit switch)		1
52	JWBS18-145E	Door Hinge Pin		1
54	TS-0267041	Socket Set Screw	1/4-20 x 3/8	1
55	JWBS18-39A	Door Hinge Pin		2
56	JWBS18-154E	Screw	1/4-20x5/8	4

Lower Wheel and Motor Assembly

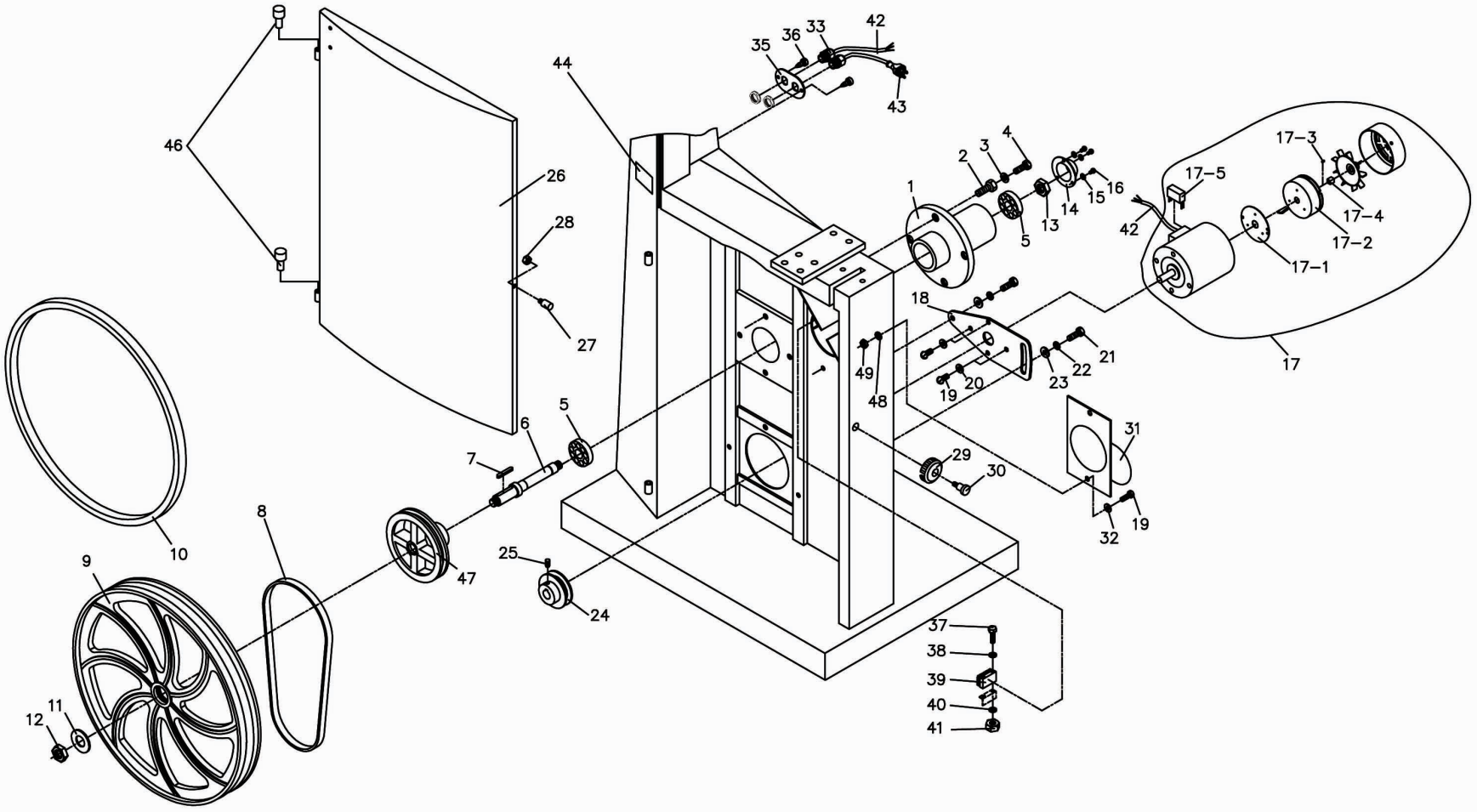

Lower Wheel and Motor Assembly

Index	Part			
No.	No.	Description	Size	Qty.
1	JWBS20-201	Bearing Base		1
2	JWBS20-62	Adjusting Bolt		4
3	TS-0720091	Lock Washer	3/8	4
4	TS-0060081	Hex Cap Bolt	3/8-16x1-3/4	4
5	BB-6206ZZ	Ball Bearing	6206	2
6	JWBS20-206	Spindle		1
7	JWBS20-49	Key	7 x 7 x 25	1
8	VB-B42	V-Belt	B-42	1
9	JWBS20-532	Lower Wheel		1
10	JWBS20-21	Tire		1
11	TS-0680091	Flat Washer	3/4	1
12	JWBS20-22	Hex Nut	3/4-16 UNF L.H.	1
13	JWBS20-214	Hex Nut	3/4-16 UNF R.H.	1
14	JWBS20-215	Bearing Cover		1
15	TS-0720071	Lock Washer	1/4	3
16	JWBS20-217	Hex Cap Bolt	1/4-20x3/8	3
17	JWBS20X-218E	Motor	2HP, 1Ph, 230V	1
	JWBS20X-218AE	Motor	3HP, 3Ph, 400V	1
	JWBS20-RCE	Running Capacitor (not shown)	30uF, 450V	1
	JWBS20-CCE	Capacitor Cover (not shown)		1
	JWBS20X-FAN	Fan (not shown)		1
	JWBS20X-MFC	Motor Fan Cover (not shown)		1
17-1	JWBS18DX-PE	Plate		1
17-2	JWBS18DX-BME	Brake Magnet		1
17-3	JWBS18DX-KE	Key		1
17-4	JWBS18DX-BE	Block		1
17-5	JWBS18DX-RE	Rectifier		1
18	JWBS18-219A	Motor Bracket		1
19	TS-0081031	Hex Cap Bolt	5/16-18x3/4	4
20	TS-0680031	Flat Washer	5/16	4
21	TS-0060051	Hex Cap Bolt	3/8-16x1	2
22	TS-0720091	Lock Washer	3/8	2
23	TS-0680041	Flat Washer	3/8	2
24	JWBS20X-224E	Motor Pulley		1
25	TS-0270031	Set Screw	5/16-18x3/8	4
26	JWBS20X-227E	Lower Front Door		1
27	JWBS20-542	Door Stud		1
28	TS-0561011	Hex Nut	1/4-20	1
29	JWBS20-2	Lock Knob		1
30	JWBS20-3	Screw	1/4-20x3/4	1
31	JWBS18-232E	Dust Chute		1
32	TS-0680031	Flat Washer	5/16	2
33	54A-S39	Strain Relief Bushing	PG11	2
35	JWBS18DX-235E	Plate		1
36	TS-082C032	Screw	#10-24x1/2	2
37	TS-018C082	Screw	#10-24x1-1/2	2
38	TS-0680011	Flat Washer	#10	2
39	JWBS18-240	Brush		1

Index Part

No.	No.	Description	Size	Qty.
40	JWBS18-241	Lock Washer	#10	2
41	TS-0560071	Hex Nut	#10	2
42	JWBS18DX-243E	Motor Cord (Motor to switch)	1Ph	1
	JWBS18DX-243AE	Motor Cord (Motor box to switch)	3Ph	1
43	JWBS18DX-244E	Power Cord	1Ph	1
	JWBS18DX-244AE	Power Cord	3Ph	1
44	JWBS20X-244E	I.D Label	1Ph	1
	JWBS20X-244AE	I.D Label	3Ph	1
46	JWBS18-39A	Door Hinge Pin		2
47	JWBS20-258	Spindle Pulley		1
48	TS-0720081	Lock Washer	5/16	1
48	TS-0561021	Hex Nut	5/16	1

Blade Guides Assembly

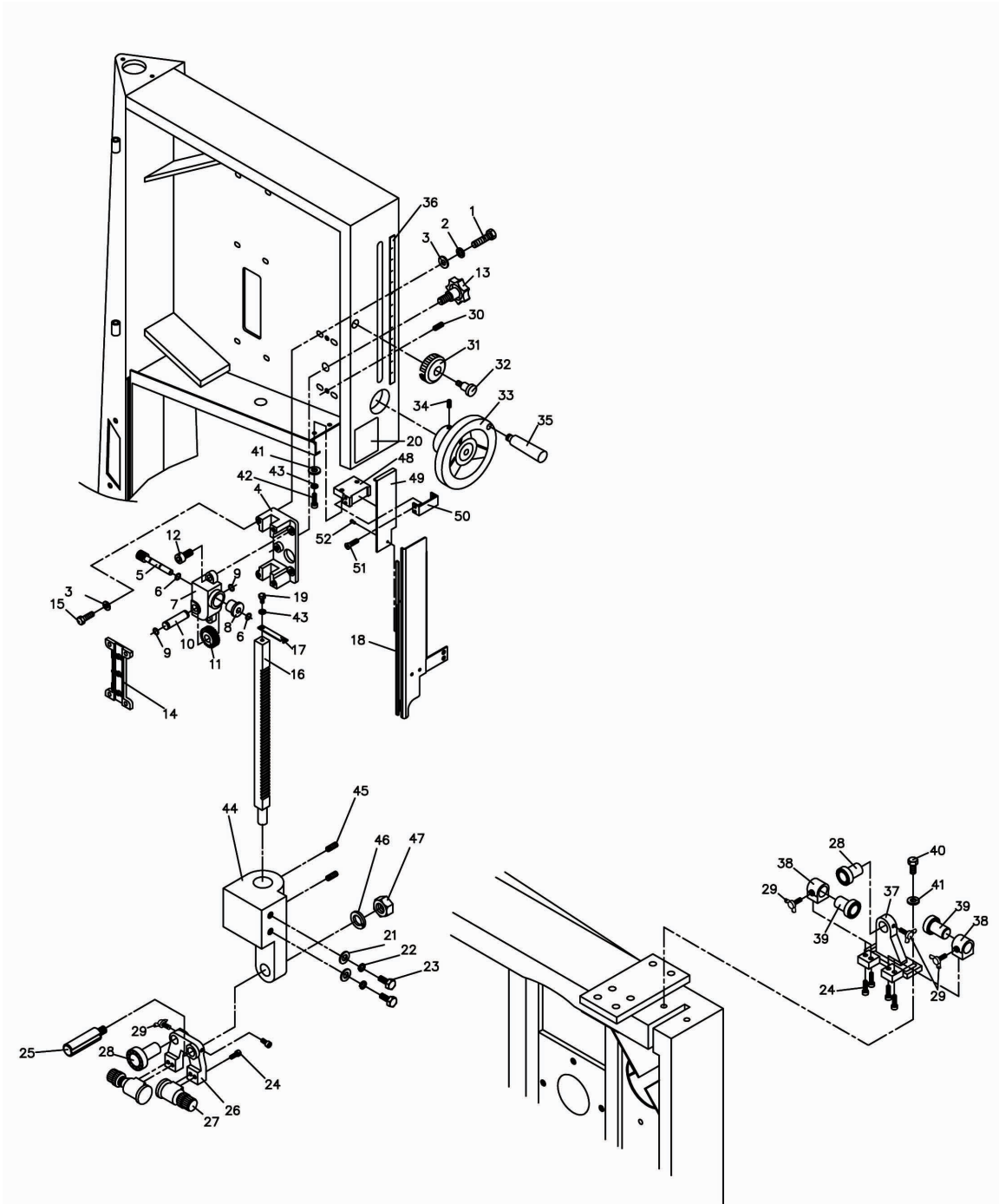

Blade Guides Assembly

Index	Part			
No.	No.	Description	Size	Qty.
1	TS-0051051	Hex Cap Bolt	5/16-18x1	4
2	TS-0720081	Lock Washer	5/16	4
3	TS-0680031	Flat Washer	5/16	8
4	JWBS20-304	Guide Bar Bracket		1
5	JWBS18-305	Worm		1
6	JWBS18-306	E-Ring	E-8	2
7	JWBS18-307	Gear Base		1
8	JWBS18-308	Bushing		1
9	JWBS18-309	C-Ring	S-12	2
10	JWBS18-310	Shaft		1
11	JWBS18-311	Gear		1
12	TS-0208071	Socket Head Cap Screw	5/16-18x1-1/4	2
13	JWBS20-313	Lock Knob	5/16	1
14	JWBS20-314	Plate		1
15	TS-0051011	Hex Cap Bolt	5/16-18x1/2	4
16	JWBS20-316	Guide Bar		1
17	JWBS20-317E	Pointer		1
18	JWBS20-318E	Blade Guard		1
19	TS-0050011	Hex Cap Bolt	1/4-20x1/2	1
20	JWBS18-348E	Blade Direction Label		1
21	TS-0680021	Flat Washer	1/4	4
22	TS-0720071	Lock Washer	1/4	2
23	TS-0050021	Hex Cap Bolt	1/4-20x5/8	2
24	TS-0207021	Socket Head Cap Screw	1/4-20x1/2	9
25	JWBS20-325	Bracket Shaft		1
26	JWBS20-115	Upper Guide Bracket		1
27	JWBS20-114	Guide Wheel Assembly		2
28	JWBS20-113	Blade Support Shaft w/ Bearing		2
29	JWBS18-329	Wing Screw	1/4-20x1/2	4
30	TS-0267041	Set Screw	1/4-20x3/8	2
31	JWBS20-2	Lock Knob		1
32	JWBS20-3	Screw	1/4-20x3/4	1
33	JWBS18-333	Hand Wheel		1
34	TS-0267041	Set Screw	1/4-20x 3/8	1
35	JWBS18-335	Handle		1
36	JWBS20-336E	Cutting Height Scale		1
37	JWBS20-120	Lower Guide Bracket		1
38	JWBS18-338	Lower Guide Wheel Housing		2
39	JWBS18-339	Lower Guide Wheel Assembly		2
40	TS-0207031	Socket Head Cap Screw	1/4-20x5/8	2
41	TS-0680021	Flat Washer	1/4	4
42	TS-0050021	Hex Cap Bolt	1/4-20x5/8	2
43	TS-0720071	Lock Washer	1/4	3
44	JWBS20-344	Guide Bar Bracket		1
45	JWBS20-345	Set Screw	5/16-18x3/8	2
46	TS-0720111	Lock Washer	1/2	1
47	TS-0561051	Hex Nut	1/2	1
48	JWBS20-348E	Upper Guard Bracket		1

Index Part

No.	No.	Description	Size	Qty.
49	JWBS20-349E	Upper Blade Guard		1
50	JWBS18-347E	Bracket Cover		1
51	JWBS18-345E	Philips Screw	#10-24x3/8	4
52	JWBS18-352E	Pin	3x12	1

Table and Fence Assembly

Index	Part			
No.	No.	Description	Size	Qty.
1	JWBS18-401	Lock Knob		1
2	TS-0680021	Flat Washer	1/4	20
3	JWBS18-403	Miter Gauge Body		1
4	JWBS20-156	Guide Disc		1
5	JWBS18-405	Pan Head Screw	M6x8	1
6	JWBS18-406	Pointer		1
7	JWBS18-407	Guide Bar		1
8	JWBS18-408N	Trunnion Support Bracket		1
9	TS-0051071	Hex Cap Bolt	5/16-18 x 1-1/2	3
10	TS-0720081	Lock Washer	5/16	8
11	TS-0270061	Set Screw	5/16-18 x 5/8	2
12	TS-0060111	Hex Cap Bolt	3/8-16 x 2-1/2	1
13	TS-0561031	Hex Nut	3/8-16	1
14	TS-0720091	Lock Washer	3/8	1
15	JWBS18-415	Lock Knob		2
16	JWBS18-416	Trunnion		2
17	JWBS18-417	Trunnion Clamp Shoe		2
18	TS-1491081	Hex Cap Bolt	M10 x 50	2
19	TS-1503041	Socket Head Cap Screw	M6x12	6
20	JWBS18-420	Scale		1
21	JWBS20-421	Table		1
22	JWBS18-422	Front Rail		1
23	TS-0050021	Hex Cap Bolt	1/4-20 x 5/8	9
24	TS-0720071	Lock Washer	1/4	20
25	JWBS18-425E	Scale		1
26	JWBS20-426	Guide Rail		1
27	JWBS18-427	Rear Rail		1
28	JWBS20-144	Table Insert		1
	JWBS20-144E	Narrow Table Insert		1
29	JWBS20-145	Roll Pin	3x10	1
30	JWBS18-430	Fence Body		1
31	JWBS18-431	Knob		1
32	JWBS18-432	Lock Handle		1
33	JWBS18-433	Lock Plate		1
34	JWBS18-434	Pad		5
35	JWBS18-435	Pin		1
36	JWBS18-436	Pin		1
37	JWBS20-437EA	Fence		1
38	TS-0208041	Socket Head Cap Screw	5/16-18x3/4	4
40	TS-0810012	Screw	#10-24x1/4	2
41	TS-0733031	Star Washer	#10	1
42	JWBS18-442	Pointer		1
43	TS-0561011	Hex Nut	1/4-20	6
44	JWBS18-444	Sliding Pad		1

Index Part

No.	No.	Description	Size	Qty.
45	JWBS18-445	Rear Hook		1
46	JWBS18-446	Pointer		1
47	JWBS18-447	Screw	M5x8	1
48	JWBS18-448	Table Pin		1
49	JWBS18-449E	Resaw Post		1
50	JWBS18-450	Lock Knob		1
51	JWBS18-451	JET Fence Label		1
52	JWBS18-452E	Lower Blade Guard		1
54	TS-0051091	Hex Cap Bolt	5/16-18x2	3
55	2013-285	End Cover		2
56	JWBS18DX-462E	Sucker (not shown)		1
	JWBS18-MGCP	Miter Gauge Assembly		
	JWBS18-FCPE	Fence Assembly Complete		
	JWBS18-APE	Accessory Package		

JWBS-20X 708752XM

230/50/1

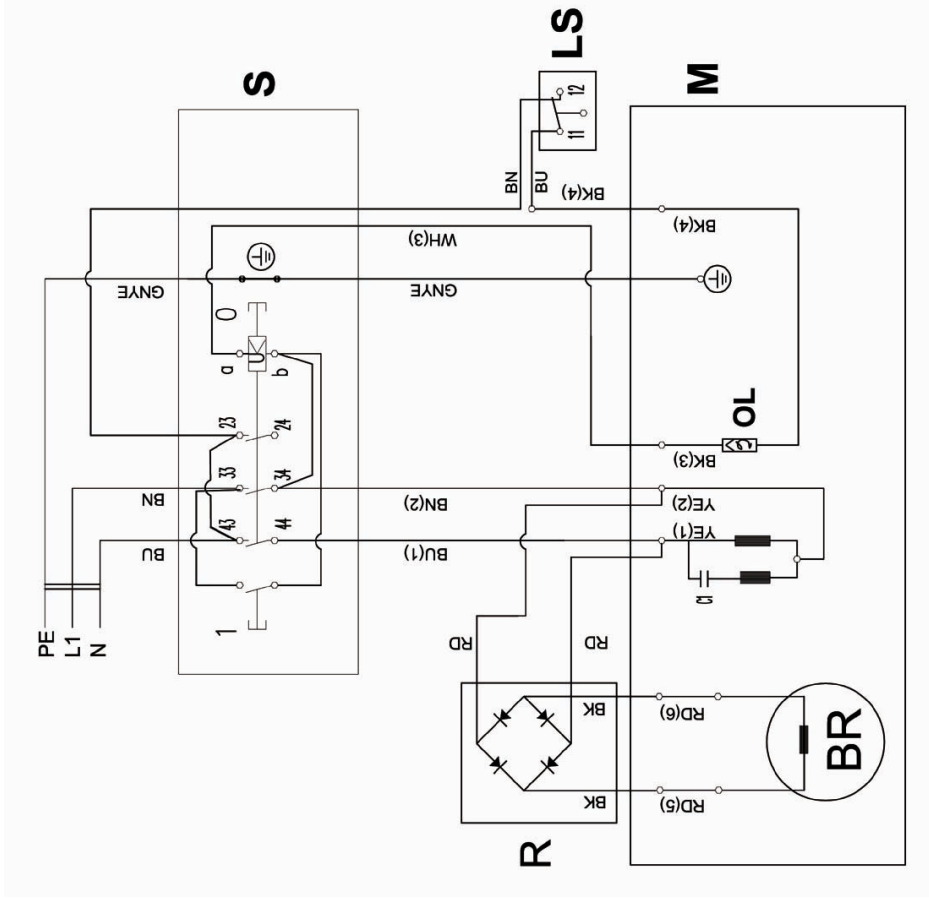

	colour of strands	Litzenfarben	couleur des cordons
BK	black	schwarz	noir
WH	white	weiß	blanc
BU	blue	blau	bleu
YE	yellow	gelb	jaune
RD	red	rot	rouge
BN	brown	braun	brun
GY	grey	grau	gris
GNYE	green-yellow	grün-gelb	vert-jaune
OG	orange	orange	orange
VT	violet	violett	violet

	meaning of symbol	Bedeutung der Zeichen	interprétation
M	motor	Motor	moteur
S	switch	Schalter	interrupteur
C	condenser	Kondensator	condensateur
R	rectifier	Gleichrichter	rectifier
BR	motor break	Motorbremse	frein de moteur
RS	reversing switch	Drehrichtungsschalter	commu. droite/gauche
CS	centrifugal switch	Fliehkraftschalter	déclencheur centrifuge
OL	overload cut-off	Überlastschuttschalter	déclencheur surcharge
LS	limit switch	Positionsschalter	micro

JWBS-20X 708752XT

400/50/3

	colour of strands	Litzenfarben	couleur des cordons
BK	black	schwarz	noir
WH	white	weiß	blanc
BU	blue	blau	bleu
YE	yellow	gelb	jaune
RD	red	rot	rouge
BN	brown	braun	brun
GY	grey	grau	gris
GNYE	green-yellow	grün-gelb	vert-jaune
OG	orange	orange	orange
VT	violet	violett	violet

	meaning of symbol	Bedeutung der Zeichen	interprétation
M	motor	Motor	moteur
S	switch	Schalter	interrupteur
C	condenser	Kondensator	condensateur
R	rectifier	Gleichrichter	rectifier
BR	motor break	Motorbremse	frein de moteur
RS	reversing switch	Drehrichtungsschalter	commu. droite/gauche
CS	centrifugal switch	Fliehkraftschalter	déclencheur centrifuge
OL	overload cut-off	Überlastschuttschalter	déclencheur surcharge
LS	limit switch	Positionsschalter	micro

