

Parts List: Planer JWP-209HH

Cutterhead Assembly

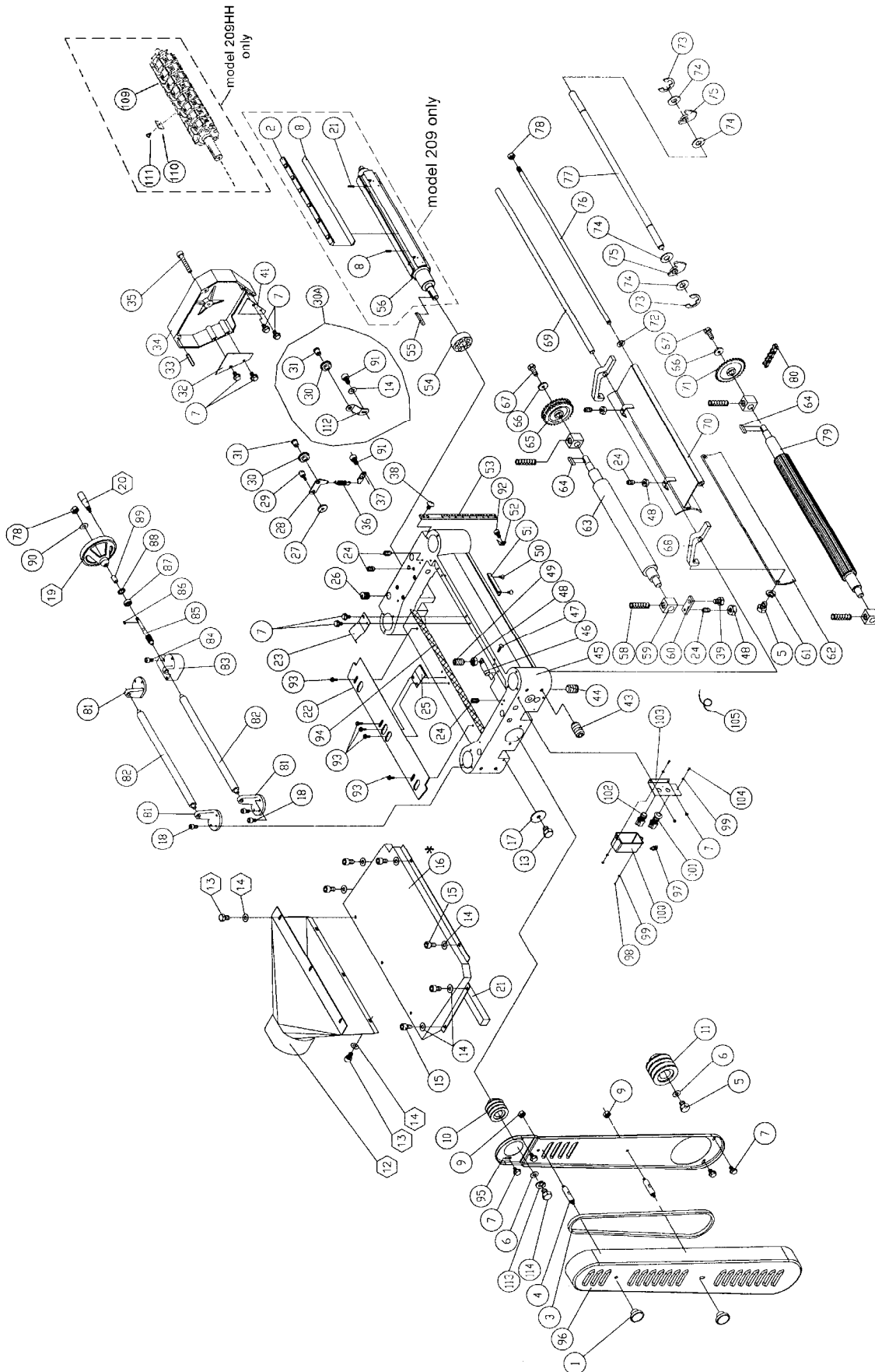

Parts List: Cutterhead Assembly

Index No.	Part No.	Description	Size	Qty
1	6012204	Nut	5/16-18NC	2
2	6292622	Knife Locking Bar *		4
3	6284811	Belt (model 209)		3
	209HH-1003	Belt (model 209HH)		3
4	6292696	Bolt		2
5	6292639	Hex Head Bolt	M8 x 1.25P x 20L	2
6	6292631	Washer	8 x 30 x 3	1
7	6292660	Hex Head Bolt With Washer	M6 x 1.25P x 20L	16
8	6292621	Knife *		4
9	6292698	Hex Nut	5/16"-18NC	2
10	6292630	Machined Pulley		1
11	6292633	Motor Pulley		1
12	6292672	Collector Tube		1
13	6292654	Hex Head Bolt	M6 x 1.0P x 12L	10
14	6292653	Washer	1/4	12
15	TS-1482011	Hex Cap Screw	M6 x 1.0P x 10L	6
16	6292670	Upper Cover		1
17	6292814	Flat Washer	8.5 x 23 x2T	4
18	7292675	Hex Cap Screw	M6 x 1.0P x 16L	9
19	6292682	Handwheel		1
20	6292684	Handle		1
21	6292620	Spring *		8
22	6292663	Chip Deflector		1
23	6292652	Plate Spring		3
24	6292640	Set Screw	M6 x 1.0P x 16	9
25	6292662	Plate Spring	0.6	1
26	6292637	Screw	M22 x 1.5P x 20	4
27	6292720	Collar		1
28	6292716	Bracket		1
29	6292717	Shaft		1
30A	209HH-IPA	Idle Pulley Assembly – model 209HH (index no. 14,30,31,91,112)		1
30	6292715	Idle Pulley		2
31	6292714	Shaft		2
32	6292693	Safety Hatch		1
33	6292690	Spring Pin	6 Dia x20	2
34	6292689	Cover		1
35	6292694	Socket Head Cap Screw	M8 x 1.25P x 40L	1
36	6292719	Spring		1
37	6292718	Hanger		1
38	6292817	Round Head Screw	M6 x 1.0P x 12L	1
39	6292818	Hex Head Bolt	M8 x 1.25P x 18L	4
41	6296255	Safety Hatch		1
43	6292618	Set Screw	M10 x 1.5P x 12L	8
44	TS-1524031	Set Screw	M8 x 1.25P x 12L	5
45	6292617	Casting Head		1
46	6292659	Shaft		2
47	6292705	Rivet		4
48	6292641	Hex Nut	M6 x 1.0P	8
49	6292661	Set Screw	M6 x 1.0 x 20L	2
50	6292669	Flat Head Machine Screw	M6 x 0.8P x 8L	2
51	6292668	Cut Limiter Plate		1
52	6292687	Cut Limiter Pointer		1
53	6292685	Scale		1
54	BB-6206ZZ	Bearing	6206ZZ-2NSE	1
55	6292629	Key	8 x 8 x 36	1
56	6292619	Cutterhead *		1

* Index Nos. 2, 8, 21 and 56 are used only on the Model 209 Planer.

Parts List: Cutterhead Assembly

Index No.	Part No.	Description	Size	Qty
58	6292636	Spring		4
59	6292635	Bushing		4
60	6292638	Plate		4
61	6292658	Lock Washer		2
62	6292657	Pressure Plate		1
63	6292646	Outfeed Roller		1
64	6292642	Key	5 x 5 x 23	2
65	6292647	Sprocket		1
66	6292644	Washer	6.2 x 20 x 3T	2
67	6292645	Hex Head Bolt	M6 x 1.0P x 16L	2
68	6292656	Bracket		1
69	6292655	Shaft		1
70	6292650	Chip Breaker		1
71	6292643	Sprocket	31T	1
72	6292649	Retaining Ring	STW-12	2
73	6292667	Retaining Ring		2
74	6292665	Collar		56
75	6292664	Anti-kickback Finger		55
76	6292648	Locking Bolt		1
77	6292666	Shaft		1
78	6292651	Nut	M12 x 1.75P	2
79	6292634	Infeed Roller		1
80	6292706	Chain	06B	1
81	6292673	Roller Stand		3
82	6292674	Roller		2
83	6292678	Gear Box Worm		1
84	6292677	Hex Socket Cap Screw	M6 x 1.0P x 50L	3
85	6292676	Worm		1
86	6292681	Key	4 x 4 x 10	1
87	6292679	Bearing	6201Z	1
88	6292680	Retaining Ring	RTW-32	1
89	6292713	Collar		1
90	6292683	Washer	1/2	1
91	6292813	Hex Socket Cap Screw	M6 x 1.0P x 10L	1
92	6292821	Hex Socket Cap Screw	M5 x 0.8P x 10L	3
93	6292815	Hex Head Bolt	M6 x 1.0P x 16L	5
94	209-1094	Sponge		2
95	209-1095	Pulley Guard		1
96	209-1096	Pulley Cover		1
97	209-1097	Strain Relief, Momentary Switch Cord		1
98	TS-1540031	Hex Nut	M5 x 0.8P	2
99	TS-1550031	Flat Washer	5 x 12 x 0.8T	4
100	209-1100	Switch Box		1
101	209-1101	Switch, Off		1
102	209-1102	Switch, On		1
103	209-1103	Switch Plate		1
104	TS-1481041	Hex Cap Screw	M5 x 0.8P x 16L	2
105	209-1105	Cord		1
106	6012192	Warning Label		1
107	6292820	Label		1
108	6292819	Label, Lubrication		1
109	1791275	Helical Cutterhead **		1
110	1791212	Knife Insert (set of 10) **		total 132
111	15HH-2102	Knife Insert Screw **		132
112	209HH-1112	Bracket		1
113	TS-2361081	Lock Washer	M8	1
114	TS-1490051	Hex Cap Screw	M8 x 1.25P x 30	1

** Index Nos. 109, 110 and 111 are used only on the Model 209HH helical cutterhead.

Base Assembly

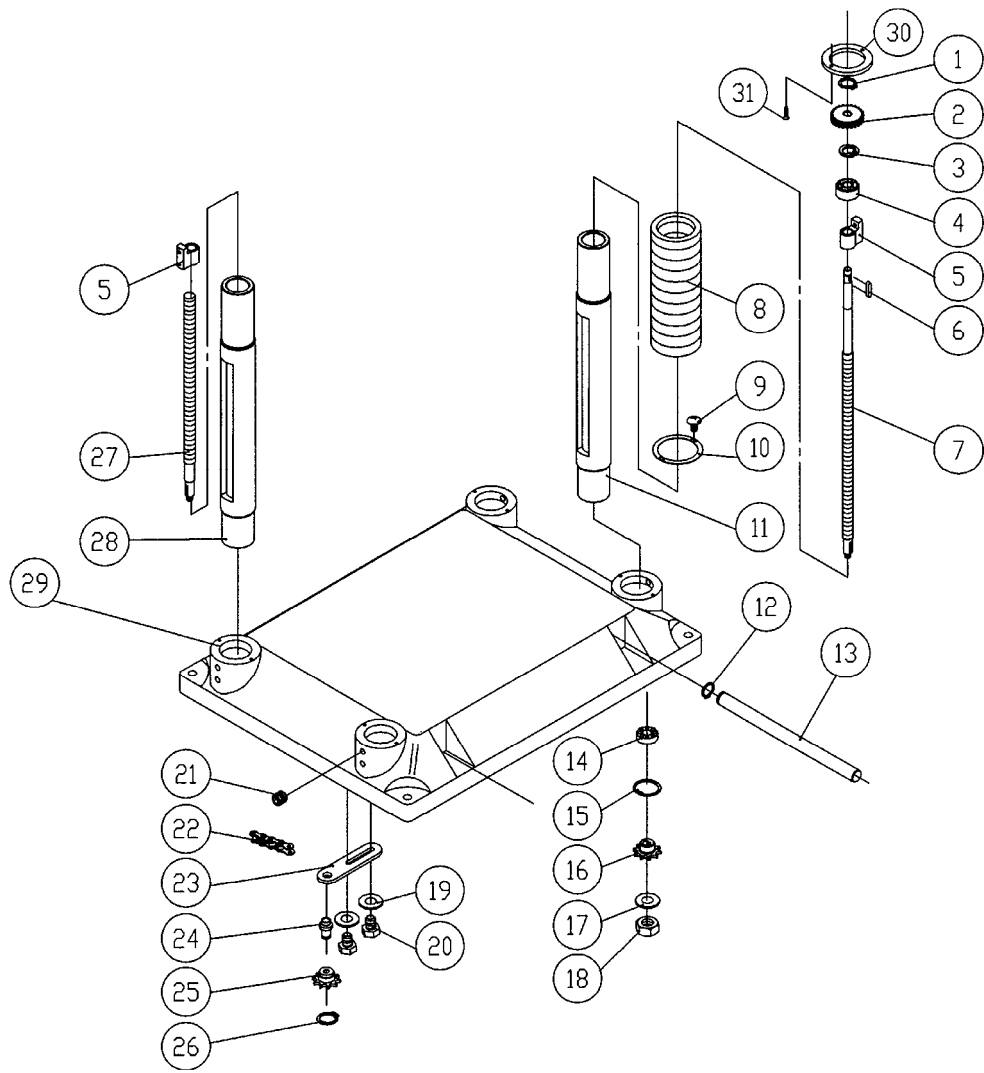

Parts List: Base Assembly

Index No.	Part No.	Description	Size	Qty
1	6292649	Ring, Retaining	STW-12	1
2	6292742	Gear	24T	1
3	6292740	Retaining Ring	RTW-38	1
4	6292739	Bushing		1
5	6292738	Nut		4
6	6292741	Key	4 x 4 x 10	1
7	6292737	Lead Screw		1
8	6292758	Expansion Bend		8
9	209-309	Machined Screw	M5 x 2.12P x 10L	30
10	6292756	Pipe Band		16
11	6292735	Column		1
12	6292755	Retaining Ring, ETW-19		4
13	6292754	Crane Post		4
14	6285855	Bearing	6202ZZ	4
15	6292744	Retaining Ring, RTW-35		4
16	6292746	Sprocket	10T	4
17	209-317	Flat Washer	10 x 19 x 1.5T	4
18	6292627	Hex Nut	M10 x 1.25P	4
19	6292747	Flat Washer	8.2 x 22 x 3T	2
20	6292748	Hex Head Bolt	M8 x 1.25P x 25L	2
21	6292618	Set Screw	M10 x 1.5P x 12	8
22	6292753	Chain	40 x 166P	1
23	6292749	Bracket		1
24	6292750	Shaft		1
25	6292751	Sprocket	10T	1
26	6292752	Retaining Ring	STW-15	1
27	6292736	Lead Screw		1
28	6292734	Column		3
29	6292733	Base		1
30	209-330	Gasket		1
31	209-331	Screw	M5 x 0.8P x 18L	2

Gearbox Assembly

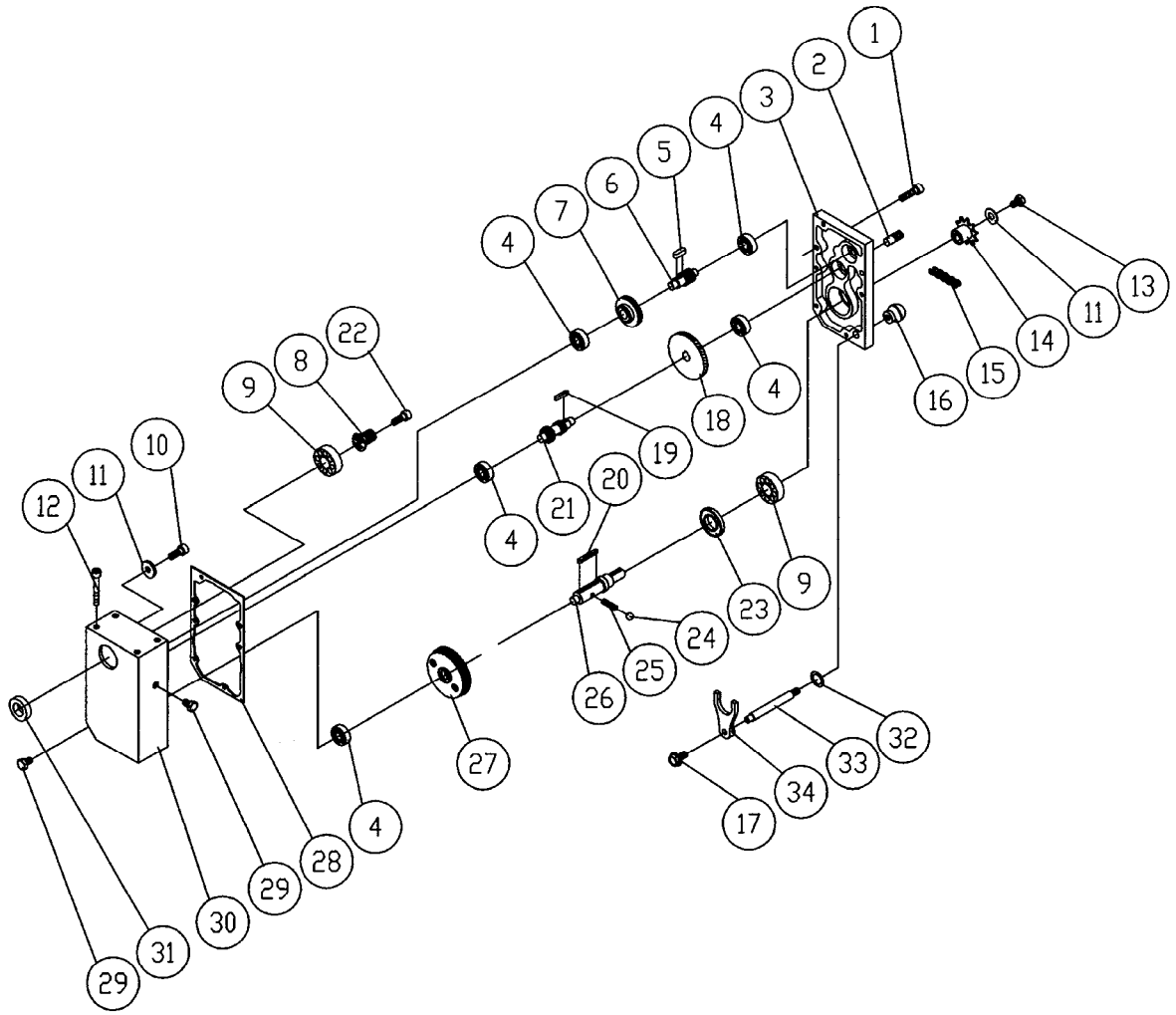

Parts List: Gearbox Assembly

Index No.	Part No.	Description	Size	Qty
1	6292788	Socket Head Cap Screw	M6 x 1.0P x 25L	5
2	6292785	Pin	8 x20	2
3	6292787	Cover		1
4	6292765	Bearing	6201	4
5	6292768	Key	5 x 5 x12	1
6	6292767	Shaft	18T	1
7	6292766	Gear	47T	1
8	6292762	Gear	16T	1
9	6292761	Bearing	6204ZZ	2
10	TS-1503041	Socket Head Cap Screw	M6 x 1.0P x 16L	1
11	6292764	Flat Washer		1
12	6292790	Hex Socket Cap Screw	M8 x 1.25P x 50L	4
13	TS-1482031	Hex Head Bolt	M6 x 1.0P x 16L	1
14	6292779	Sprocket	12T	1
	6292791	Sprocket	18T	1
15	6292780	Chain	06B x 50P	1
	6292792	Chain (model 209 only)	06B x 52P	1
	209HH-415	Chain (model 209HH only)	06B x 53P	1
	6292822	Low Speed Gear Kit (includes #14-6292779 and #15-6292780)		
16	6292784	Knob		1
17	6292654	Hex Head Bolt	M6 x 1.0P x 12L	1
18	6292769	Gear	71T	1
19	6292770	Key	5 x 5 x 10	1
20	6292774	Key	6 x 6 x 40	1
21	6292771	Shaft	18T	1
22	6292763	Hex Socket Cap Screw	M6 x 1.0P x 20L	1
23	6292778	Oil Seal	SC24 x 47 x 6	1
24	6292775	Ball	Ø 6	1
25	6292776	Spring		1
26	6292777	Shaft		1
27	6292772	Gear Assembly		1
28	6292786	Piece Packing		1
29	6292789	Oil Plug	PT1/4"-19	2
30	6292759	Gear Box		1
31	6292760	Oil Seal		1
32	6292783	Oil Ring		1
33	6292782	Handle		1
34	6292781	Clutch		1

Stand Assembly

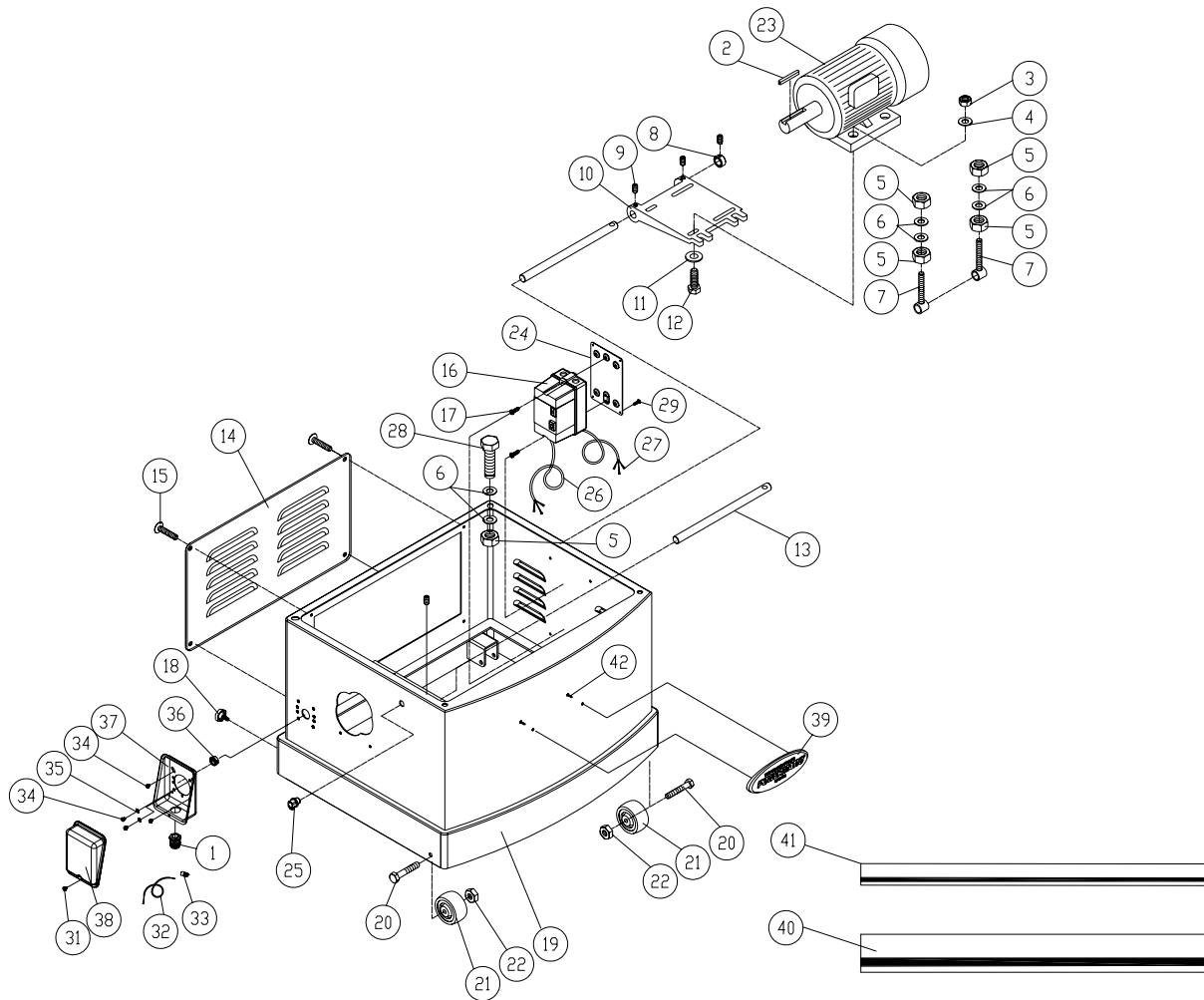

Parts List: Stand Assembly

Index No.	Part No.	Description	Size	Qty
1	6292807	Strain Relief		1
2	6292804	Key		1
3	6292802	Hex Nut	M8 x 1.25P	4
4	TS-1550061	Flat Washer	8.5 x 16 x 1.5T	4
5	6292651	Hex Nut	M12 x 1.75P	8
6	6292683	Washer	1/2	12
7	6292799	Adjusting Bolt		2
8	6292798	Collar		1
9	6292711	Set Screw	M8 x 1.25P x 8L	5
10	6292797	Motor Mount (model 209 only)		1
	209HH-5010	Motor Mount (model 209HH only)		1
11	TS-1550061	Washer	8.5 x 23 x 2T	4
12	TS-1490071	Hex Head Bolt	M8 x 1.25P x 40L	4
13	6292796	Bar		2
14	6292794	Cover		1
15	6292795	Machine Screw	M6 x 1.0P x 20	4

Parts List: Stand Assembly

Index No.	Part No.	Description	Size	Qty
16	209-5016B	Magnetic Switch	5HP 1PH 230V	1
	JWP208-087E	Magnetic Switch	5HP 3PH 230/460V	1
17	6296136	Pan Head Machine Screw	#10-24NC x 1/2L	2
18	209-5018	Lock Knob	5/16-18NC x 3/4	2
19	209-5019	Stand (model 209 only)		1
	209HH-5019	Stand (model 209HH only)		1
20	TS-1490031	Hex Cap Screw	M8 x 1.25P x 20	4
21	209-5021	Wheel		4
22	TS-1541031	Nylon Hex Nut	M8	4
23	209-5023	Motor (209)	5HP, 1Ph, 230V	1
	209-5023F	Motor Fan (not shown)		1
	209-5023FC	Motor Fan Cover (not shown)		1
	209-5023CS	Centrifugal Switch (not shown)		1
	209-5023SC	Start Capacitor (not shown)		1
	209-5023RC	Running Capacitor (not shown)		1
	209-5023A	Motor (209)	5HP, 3Ph, 230/460V	1
	209-5023F	Motor Fan (not shown)		1
	209-5023FC	Motor Fan Cover (not shown)		1
	209HH-5023	Motor (209HH)	5HP, 1Ph, 230V	1
	209HH-5023F	Motor Fan (not shown)		1
	209HH-5023FC	Motor Fan Cover (not shown)		1
	209HH-5023CS	Centrifugal Switch (not shown)		1
	209HH-5023SC	Start Capacitor (not shown)		1
	209HH-5023RC	Running Capacitor (not shown)		1
	209HH-5023A	Motor (209HH)	5HP, 3Ph, 230/460V	1
	209HH-5023F	Motor Fan (not shown)		1
	209HH-5023FC	Motor Fan Cover (not shown)		1
24	209-524	Switch Plate		1
25	209-1097	Strain Relief, Momentary Switch Cord		1
26	209-526	Power Cord		1
27	209-527	Cord, Motor to Switch		1
28	6292805	Hex Head Bolt	M12 x 1.75P x 60L	4
29	6292757	Machined Screw	M5 x 0.8P x 8L	4
31	TS-0810012	Slotted Round Head Machine Screw	#10-24 x 1/4	1
32	209-5032	Grounding Cord		1
33	209-5033	Cord Connection		1
34	209-5034	Screw	M5 x 0.8P x 6	4
35	209-5035	Star Washer	M5	2
36	209-5036	Strain Relief		1
37	209-5037	Junction Box		1
38	209-5038	Junction Box Cover		1
39	PM2000-105	Powermatic Name Plate		1
40	PM2700-440	Wide Stripe		<i>sold per ft.</i>
41	PM2700-441	Narrow Stripe		<i>sold per ft.</i>
42	TS-0813022	Pan Head Screw	1/4-20 x 3/8	2

Parts List: Table Assembly

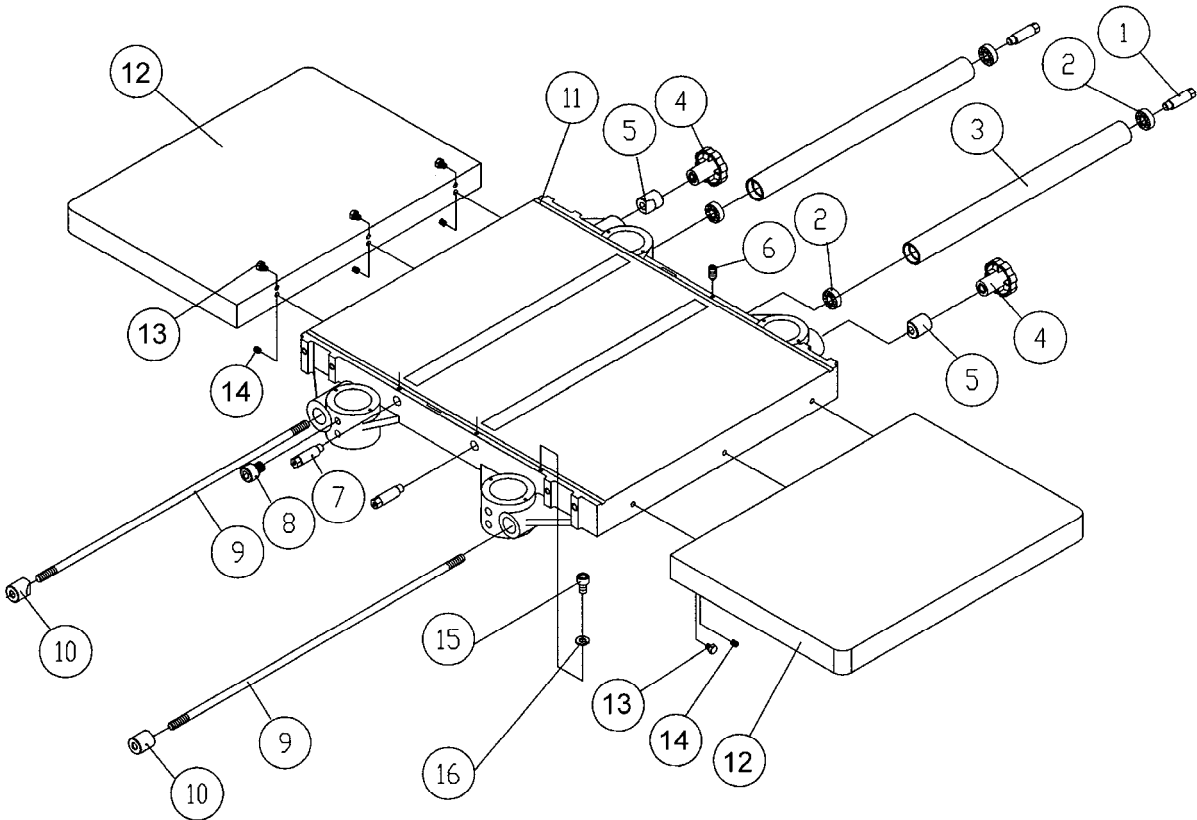

Index No.	Part No.	Description	Size	Qty
1	6292724	Eccentric Shaft		4
2	6292679	Bearing	6201Z	4
3	6292722	Roll		2
4	6292728	Knob		2
5	6292727	Locksmith		2
6	TS-1523041	Set Screw	M6 x 1.0P x 12L	4
7	6292724	Eccentric Shaft		4
8	6292729	Socket Head Cap Screw	M8 x 1.25P x 16L	8
9	6292726	Locking Bolt		2
10	6292725	Locking Bar		2
11	209-2011	Table		1
12	209-2012	Extension		2
13	TS-1490041	Hex Cap Screw	M8 x 1.25P x 25L	6
14	TS-1504041	Socket Head Cap Screw	M8 x 1.25P x 20L	6

Electrical Connections – 3 Phase, 380 Volt only

